

Specifications

Conditions of Sale

STANDARD: The seller's standard conditions of sale set forth in Price Sheets 150 and 181 apply, except as modified by the "Special Warranty Provisions" section on page 7 and "Warranty Qualifications" section on page 8.

SPECIAL TO THIS PRODUCT AND ASSOCIATED SERVICES:

INCLUSIONS: The IntelliRupter PulseCloser Fault Interrupter is a unitized package of fault-interrupting and control components that provides fault-isolation and circuit-restoration functions on an overhead distribution system. It can operate as a stand-alone fault interrupter or, with appropriate options, be integrated into a SCADA system and/or an IntelliTeam® SG Automatic Restoration System.

The IntelliRupter fault interrupter features PulseClosing® Technology—a unique means for verifying the line is clear of faults before initiating a close operation. PulseClosing Technology is superior to conventional reclosing techniques. It greatly reduces stress on system components as well as voltage sags experienced by customers upstream of the fault.

The IntelliRupter fault interrupter provides full live-switching performance under all ice conditions. The circuit making, circuit breaking, and circuit testing done using PulseClosing Technology are accomplished within the interrupters; there are no external moving parts.

Each IntelliRupter fault interrupter is factory assembled on a single stainless steel base with:

- Three-pole vacuum interrupters
- Unique magnetic latching actuators that provide single-phase tripping/single-phase lockout, single-phase tripping/three-phase lockout, or three-phase tripping/three-phase lockout of the interrupters (The interrupters can also be manually tripped by means of a manual lever operable from the ground with an extendostick.)

- Sensors for three-phase monitoring of line current and three-phase monitoring of line voltage on both sides of the interrupters that provide high accuracy sensing (Total sensing system accuracy is $\pm 0.5\%$ for steady-state current and $\pm 2\%$ for fault current.)
- One or two integral power modules, which derive the necessary energy directly from the distribution line (Control power can alternately be derived from an external power supply.)
- An OPEN/CLOSED indicator for each phase
- An external power supply connector that permits pre-installation uploading and downloading of configuration settings, plus radio programming and battery charging, as applicable, indoors in the user's service center or lab
- A manually actuated OPEN/CLOSE/READY lever operable from the ground with an extendostick
- A manually actuated GROUND TRIP BLOCK lever operable from the ground with an extendostick
- A manually actuated HOT-LINE TAG lever, also operable from the ground with an extendostick, to enable or disable a hot-line tag or to disable an electronically set hot-line tag
- A control group featuring a hookstick-removable protection and control module and a communication module mounted in the base (The IntelliRupter fault interrupter is easily configured and operated from the safety and security of a vehicle parked near the base of the pole by means of a secure Wi-Fi communication link to a laptop computer.)
- A unique multifunction status light that indicates control group operation (The blink rate changes if a Wi-Fi connection is made, control power is lost, or the OPEN/CLOSE/READY lever is operated. A separate HOT-LINE TAG indicator shows a "set" tag.)
- An integrated Global Positioning System (GPS) that provides 1-ms accurate time-stamping of events to speed post-event analysis as well as IntelliRupter fault interrupter location data for entry in the user's graphical information system



Conditions of Sale—Continued

- Provisions for three surge arresters on each side of the IntelliRupter fault interrupter (Surge arresters can be optionally factory-installed and wired.)
- Single-point lifting for convenient rigging and hoisting of an IntelliRupter fault interrupter during installation

The IntelliRupter fault interrupter is available in the upright-crossarm and compact-crossarm mounting configurations, with or without an integral hookstick-operated disconnect for visible air-gap isolation of switched-open circuits. The disconnect is interlocked with the interrupters to ensure pole-units are open before opening or closing the disconnect; a status point for remote monitoring of the disconnect position is included. Interrupters may be operated with the disconnect in the **Open** position.

An IntelliRupter fault interrupter may be mounted on a utility pole or, in substation applications, on an S&C Mounting Pedestal that is available separately. IntelliRupter fault interrupter pole-units are molded of Cypoxy™ Insulator material. The sensors are embedded, eliminating the cost, clutter, and complexity associated with separately mounted sensors. Sensing accuracy is $\pm 0.5\%$ for both voltage and current, and total system accuracy for fault detection, including sensing, control, and interrupting time, is $\pm 2.0\%$.

IntelliRupter fault interrupters include on-site user training on setup, configuration, and operation. This service applies to first-time orders only; it can be provided for subsequent orders as indicated in Table 13 on page 22.

Control Groups

The IntelliRupter fault interrupter is available with a variety of control groups. Each features easy configuration and operation—and examination of waveforms and events—using secure Wi-Fi communication to a nearby laptop computer. The Wi-Fi is certified for use in Australia, the Bahamas, Brazil, Canada, the European Union, Finland, India, Ireland, Norway, Paraguay, Sweden, Thailand, Turkey, the United Kingdom, and the United States of America. Contact your local S&C representative for the availability of certifications for other countries. Note that some certifications may take up to 9 months to obtain.

The protection and control module and the communication module are easily removed from the base with a module handling fitting on a hookstick. This flexible, low-maintenance arrangement offers excellent immunity to surges and noise induced by normal power line events, such as faults and lightning strikes, and minimizes pole clutter. The IntelliRupter fault interrupter is powered from the distribution line through the integral power module(s) or the external power supply, if furnished.

The protection and control module provides point-on-wave closing to minimize asymmetric fault current and inrush current. It features a complete set of protection and control functions, including:

- Simultaneous independent **Directional Phase, Ground, Negative-Sequence, Sensitive-Earth Time-Overcurrent, Instantaneous-Overcurrent, and Definite-Time** elements
- Directional blocking of **Overcurrent** elements
- **Over/Under Voltage** elements
- **Over/Under Frequency** elements
- Phase-unbalance detection
- Synchronization check
- Cold-load pickup modifier
- User-selectable single-phase or three-phase tripping at any point in the test sequence, with single-phase or three-phase lockout
- Comprehensive diagnostics, including data and waveform capture

The protection group is automatically selected in response to the system configuration for optimized protection.

The protection and control module provides sophisticated remote terminal unit functionality, including remote reporting of IntelliRupter fault interrupter status points and operations, as well as current, voltage, watts, and vars.

A 20-channel global positioning system receiver in the communication module provides 1-ms accurate time-stamping of events to speed post-event analysis as well as IntelliRupter fault interrupter location data to help maintain your graphical information system.

Select the control group that meets the requirements of your distribution system.

Standard Control Group

The Standard Control Group is suitable for the following applications:

- The IntelliTeam® SG Automatic Restoration System (Teams use peer-to-peer communication, real-time data, and distributed intelligence to make automatic operating decisions. No central processing or SCADA is required, though fully supported. Each IntelliRupter fault interrupter must be furnished with an approved communication device.)
- Automatic source transfer using two IntelliRupter fault interrupters (The IntelliRupter fault interrupters ensure a high degree of critical-load continuity by minimizing interruptions resulting from the loss of one source. Each IntelliRupter fault interrupter must be furnished with an approved communication device.)
- Automatic loop restoration using normally closed IntelliRupter fault interrupters or conventional reclosers, with a normally open IntelliRupter fault interrupter switching point (The feeder on either side of the switching point can be fed from a different source. If a fault occurs on either feeder, the normally closed devices in that feeder open and then test the circuit using PulseClosing Technology (or reclosing) sequentially to sectionalize and isolate the fault. Service is automatically restored to unfaulted line segments by closing the normally open IntelliRupter fault interrupter.)
- Wide-area SCADA, when equipped with an approved communication device
- Stand-alone (non-communicating) applications

Approved communication devices permit configuration, operation, interrogation, and software maintenance of an IntelliRupter fault interrupter from any location having access to the communication system using optional IntelliLink® Setup Software.

No batteries are required for stand-alone applications and applications with operating times of 30 seconds or less; ac line voltage must be available on the side of the IntelliRupter fault interrupter with the integral power module, or control power must be available from the external power supply, if furnished.

The Standard Control Group includes IntelliTeam SG Bronze Level Software. When furnished with optional IntelliTeam SG Silver Level Software, the Standard Control Group is additionally suitable for basic closed-loop applications. When furnished with optional IntelliTeam SG Gold Level Software, the Standard Control Group is additionally suitable for basic closed-loop applications and applications on systems with three or more sources. IntelliTeam® Designer Configuration and License Management Software is required to activate IntelliTeam SG software.

Standard Control Group with Battery Backup

This control group is identical to the Standard Control Group and is suitable for the same applications. It additionally includes batteries that support operation for a minimum of four hours after loss of ac line voltage on both sides of the IntelliRupter fault interrupter, permitting extended dead-line switching.

Universal Control Group

This control group is identical to the Standard Control Group with Battery Backup but includes either IntelliTeam SG Gold Level Software and IntelliTeam Designer Configuration and License Management Software or an IntelliTeam® II Automatic Restoration System Software License, as specified. When the former is specified, the Universal Control Group is suitable for all applications of the Standard Control Group with Battery Backup, as well as basic closed-loop applications and applications on systems with three or more sources. When the latter is specified, the Universal Control Group is suitable for all IntelliTeam II applications.

Services-Only Packages

Services-only packages are also available for the IntelliRupter fault interrupter, as listed in Table 13 on page 22. Offerings include:

- Communication site surveys
- Overcurrent protective device coordination studies
- IntelliTeam SG system device settings determination
- IntelliRupter fault interrupter secondary injection testing
- IntelliTeam SG system factory-acceptance testing
- IntelliTeam SG system training
- IntelliTeam SG system commissioning

- IntelliTeam SG system SCADA integration
- IntelliTeam SG system monitoring
- Loop restoration training
- IntelliRupter fault interrupter training
- IntelliRupter fault interrupter maintenance
- IntelliRupter fault interrupter project and construction management

Communication Site Surveys

A communication site survey is required for new IntelliTeam SG system applications and is critical to ensure acceptable signal strength between the IntelliRupter fault interrupters in the team and the head-end SCADA radio, if applicable. A site survey includes:

- An engineering review of selected team member sites that considers distance, topological constraints, and other factors that can affect signal strength
- An on-site survey of team member sites to confirm feasibility and, if necessary, determination of alternative sites that will provide better signal strength
- A detailed report defining the GPS coordinates of all team and repeater radios
- Establishment of baseline communication statistics for monitoring communication system performance

The user will need to supply a line truck and the engineer/technician responsible for the project.

The site survey ensures optimal communication when the system is commissioned. However, building construction, relocation of lines, vegetation growth, and other factors can degrade communication over time. A subsequent “tune-up” site survey may be desirable.

Overcurrent Protective Device Coordination Studies

A coordination study is used to select appropriately rated protective devices and their settings, including those of IntelliRupter fault interrupters. Proper protective device coordination minimizes the impact of short-circuits by isolating faults as quickly as possible while maintaining power to the rest of the system.

IntelliTeam SG System Device Settings Determination

Appropriate device settings are essential to the successful implementation of the IntelliTeam SG Automatic Restoration System. These settings must be documented before factory acceptance testing and commissioning of the IntelliTeam SG Automatic Restoration System.

IntelliRupter Fault Interrupter Secondary Injection Testing

Secondary injection testing validates the settings, functions and logic of an IntelliRupter fault interrupter protection and control module before installation, and it helps ensure successful commissioning. It can also be performed when the user's operating practices require periodic testing of installed equipment to validate control and coordination settings. The procedure uses Omicron testing equipment with a specially designed interface to the IntelliRupter fault interrupter docking station.

The user must provide the following a minimum of two weeks before commencement of this service:

- Availability of the user's designee, who will be the point of contact for S&C's field service specialist
- Proposed settings for each protection and control module to be tested; determination of these settings is the responsibility of the user's designee, or it can be provided by S&C
- A written description of the desired test plan
- Indoor access to each protection and control module to be tested

S&C will prepare a report detailing the results of the testing for each protection and control module.

IntelliTeam SG System Factory Acceptance Testing

Factory acceptance testing ensures all information required for a successful IntelliTeam SG system implementation is gathered and understood before commissioning and is strongly recommended if there are any unusual system characteristics or loading limitations. It provides significant insight into how the IntelliTeam SG Automatic Restoration System will work on the user's system—with specific system-protection settings, available fault currents, connected loads, etc. To perform this testing, the user must furnish the following:

- Substation breaker data, including overcurrent pickup levels and relay timer settings

- Available fault current at each IntelliRupter fault interrupter location or—if S&C is providing an overcurrent protective device coordination study and/or determination of IntelliTeam SG system device settings—information that will allow S&C to calculate these values
- Any substation capacity limitations, conductor loading limitations, or system operating rule limitations
- A written description of the desired system functionality
- A single-line diagram of the circuits on which the IntelliTeam SG Automatic Restoration System will be applied
- Completed IntelliTeam SG system settings sheets; determination of device settings is the customer's responsibility, or it can be provided by S&C

Factory acceptance testing is performed at S&C's IntelliLab facility in Chicago. S&C will provide a detailed test plan. After testing has been completed, users will receive a CD-ROM containing the results of each simulation, which they can use for training.

IntelliTeam SG System Training

IntelliTeam SG system training is conducted onsite and ensures the user's personnel fully understand IntelliTeam SG system functioning. Both operations and engineering sessions are provided.

Operations training is geared toward persons who will encounter the equipment in the field, dispatch personnel, or create switching orders. A typical agenda includes:

- An IntelliTeam SG Automatic Restoration System— what it is, how it works, and examples
- Operation of IntelliRupter fault interrupters in an IntelliTeam SG system
- Real-world examples of IntelliTeam SG system operation using IntelliTeam Designer in **Instant Replay** mode

Engineering training is geared toward engineers and technicians who will configure the controls and radios. A typical agenda includes:

- A detailed look at how the IntelliTeam SG Automatic Restoration System works
- Explanation of all control settings
- Software screens useful for troubleshooting
- Configuration of the radios
- Creation of a DNP lookup table

IntelliTeam SG System Commissioning

IntelliTeam SG system commissioning ensures the IntelliRupter fault interrupters in the team have been set up correctly and are ready to be put into service. These services include:

- Assistance with configuring the IntelliRupter fault interrupters (Determination of device settings is the customer's responsibility, or it can be provided by S&C.)
- Verification of acceptable peer-to-peer communication
- Verification of acceptable communication with the SCADA system
- Checking each IntelliRupter fault interrupter for conformance with installation recommendations
- Verification that each team is capable of achieving **Ready** status (Upon user request, the teams will be disabled after verification.)

IntelliTeam SG System SCADA Integration

If the IntelliTeam SG Automatic Restoration System is to communicate with a SCADA system, integration services may be desirable. These services include:

- Working with the SCADA supplier
- Designing and installing the communication infrastructure linking the IntelliTeam SG Automatic Restoration System with the user's LAN
- Developing the protocol conversion necessary to change DNP into the native language of the SCADA master
- Developing optimal SCADA settings and polling sequence

IntelliTeam SG System Monitoring

Ongoing remote system monitoring ensures IntelliTeam SG system operation meets agreed-upon service levels. It requires a SpeedGate™ Radio Interface System with a wireless telephone modem. If wireless telephone service is not available, a telephone modem and user-supplied telephone line must be installed at the SpeedGate Radio Interface System.

System monitoring allows S&C's engineers to assist with any required troubleshooting, update configurations, and provide weekly "health reports" on the status of the system. Such reports can include:

- Team Ready status
- IntelliTeam SG system operational status
- Battery system status
- Active trouble conditions or alarms

The scope and format of the reports can be customized to meet specific user needs.

Loop Restoration Training

This training is conducted onsite and ensures the user's personnel know how to properly set up, configure, and operate IntelliRupter fault interrupters in a loop application comprised of normally closed IntelliRupter fault interrupters or conventional reclosers, with a normally open IntelliRupter fault interrupter switching point.

IntelliRupter Fault Interrupter Training

This training is conducted onsite and ensures the user's personnel know how to properly set up, configure, and operate IntelliRupter fault interrupters. These services for first-time orders include the following:

- Training on use of IntelliLink Setup Software
- Configuring the IntelliRupter fault interrupter for use in a loop restoration system, if applicable
- Use of security keys
- IntelliRupter fault interrupter operation, including PulseClosing Technology

IntelliRupter Fault Interrupter Maintenance

IntelliRupter fault interrupter maintenance includes periodic field inspection and testing on a three-year interval. Services provided on a per-unit basis include:

- Visual inspection of the IntelliRupter fault interrupter, antennas, grounding, arresters, and wiring connections
- Verification of IntelliLink Setup Software operation through secure Wi-Fi connection
- Downloading of a full report from the IntelliRupter fault interrupter, review of the data, and execution of any corrective actions necessary
- Replacement of the battery
- Operation of the IntelliRupter fault interrupter (if it can be bypassed) locally, manually, and from SCADA

- Inspection of the repeater radio and replacement of its battery
- Monitoring of communication statistics and comparison against the initial baseline. Identification of recommended communication enhancements

All system maintenance is coordinated with the user's designee. To facilitate the inspection process and ensure consistent and accurate reporting, S&C will work with the designee to develop an inspection checklist and train inspection crews on its importance and use.

IntelliRupter Fault Interrupter Project and Construction Management

S&C's highly trained, experienced staff will assist the user's automation team in the areas of project and construction management, working closely with them to ensure on-time completion of the project. Services may include working with the user's contractor or crew to:

- Ensure proper installation of the IntelliRupter fault interrupters
- Supply the automation system as a complete turnkey project

EXCLUSIONS: IntelliRupter fault interrupters do not include terminal-pad connectors. Various connectors are available as listed in Table 11 on page 20. Equipment/services packages and services-only packages do not include field installation or construction labor.

IntelliRupter fault interrupters furnished with Standard Control Group or Standard Control Group with Battery Backup do not include optional IntelliTeam SG Silver Level Software, IntelliTeam SG Gold Level Software, or IntelliTeam Designer Configuration and License Management Software.

For non-IntelliTeam SG system applications, S&C may be able to furnish and install in the communication module, or make provision for, a customer-specified communication device not listed in Table 8 on page 18. S&C will need to evaluate the physical and electrical requirements of the communication device and its performance characteristics, and conduct qualification testing to verify its suitability for the desired application. Refer to the nearest S&C Sales Office for scheduling information. S&C cannot furnish or install any communication device for which the supplier requires S&C to offer Tier I (i.e., "help desk") support.

If a licensed radio is required for a SCADA interface, the frequency selection and FCC license application are to be provided by others. S&C can provide a radio propagation study as well as a general system review to ensure optimal application of distribution automation components.

APPLICATION NOTES: The following factors should be considered when applying IntelliRupter fault interrupters:

System voltage restrictions. For adequate power to be available from the integral power module(s), an IntelliRupter fault interrupter must be applied on a system that is solidly grounded, uni-grounded, grounded through a grounding transformer, or resonant-grounded through a Petersen coil. The base of the IntelliRupter fault interrupter must be grounded, the line-to-neutral voltage must be in the range of a control power source shown in Table 3 on page 13.

When furnished with the external power supply, an IntelliRupter fault interrupter may be applied at line-to-line voltage as low as 4.13 kV, 50/60 Hz.

For application on a completely ungrounded system, the external power supply must be specified, less integral power module(s). Integral power modules cannot be applied on completely ungrounded systems.

Application of surge arresters. Surge arresters are required on both sides of an IntelliRupter fault interrupter to protect it from surges beyond its ratings. An IntelliRupter fault interrupter includes provisions for mounting three user-furnished surge arresters on each side of the device. Alternately, an IntelliRupter fault interrupter can be optionally furnished with surge arresters factory-installed and wired.

SPECIAL WARRANTY PROVISIONS: The standard warranty contained in seller's standard conditions of sale, as set forth in Price Sheets 150 and 181, applies to the IntelliRupter fault interrupter and its associated options except for the control group as applicable. For these devices, the first and second paragraphs of said warranty are replaced by the following:

(1) General: The seller warrants to the immediate purchaser or end user for a period of 10 years from the date of shipment that the equipment delivered, with the exception of a radio, will be of the kind and quality specified

in the contract description and will be free of defects of workmanship and material. Should any failure to conform to this warranty appear under proper and normal use within 10 years after the date of shipment, the seller agrees, upon prompt notification thereof and confirmation that the equipment has been stored, installed, operated, and maintained in accordance with recommendations of the seller and standard industry practice, to correct the nonconformity either by repairing any damaged or defective parts of the equipment or (at seller's option) by shipment of necessary replacement parts.

The seller's warranty does not apply to any equipment that has been disassembled, repaired, or altered by anyone other than the seller. This limited warranty is granted only to the immediate purchaser or, if the equipment is purchased by a third party for installation in third-party equipment, the end user of the equipment. The seller's duty to perform under any warranty may be delayed, at the seller's sole option, until the seller has been paid in full for all goods purchased by the immediate purchaser. No such delay shall extend the warranty period.

The seller further warrants to the immediate purchaser or end user that for a period of two years from the date of shipment the software will perform substantially in accordance with the then-current release of specifications if properly used in accordance with the procedures described in seller's instructions. The seller's liability regarding any of the software is expressly limited to exercising its reasonable efforts in supplying or replacing any media found to be physically defective or in correcting defects in the software during the warranty period. Seller does not warrant the use of the software will be uninterrupted or error-free.

For equipment/services packages, the seller warrants, for a period of one year after commissioning, that the IntelliRupter fault interrupters will provide automatic fault isolation and system reconfiguration per agreed-upon service levels. The remedy shall be additional system analysis and reconfiguration of the IntelliTeam SG Automatic Restoration System until the desired result is achieved.

WARRANTY QUALIFICATIONS: The standard warranty contained in seller's standard conditions of sale, as set forth in Price Sheets 150 and 181, does not apply to major components not of S&C manufacture, such as batteries, customer-specified remote terminal units and communication devices, as well as hardware, software, resolution of protocol-related matters, and notification of upgrades or fixes for those devices. The seller will assign to the immediate purchaser or end user all manufacturers' warranties that apply to such major components.

The seller's standard warranty does not apply to any components not of S&C manufacture that are supplied and installed by the purchaser or to the ability of seller's equipment to work with such components.

Warranty of equipment/services packages is contingent upon receipt of adequate information on the user's distribution system, sufficiently detailed to prepare a technical analysis. The seller is not liable if an act of nature or parties beyond S&C's control negatively impact performance of equipment/services packages; for example, new construction that impedes radio communication, or changes to the distribution system that affect protection systems, available fault currents, or system loading characteristics.

END USER LICENSE AGREEMENT: The end user is granted a nontransferable, non-sublicensable, nonexclusive license to use the LinkStart Connection Management Software, IntelliLink Setup Software, IntelliTeam Automatic Restoration Software, Loop Restoration Software, and/or other software furnished with an IntelliRupter PulseCloser Fault Interrupter only upon acceptance of all the terms and conditions of the seller's end user license agreement set forth in Price Sheet 155 and Price Sheet 156.

How to Order an IntelliRupter Fault Interrupter

Complete these steps to identify the base catalog number, the appropriate options, and the product accessories to complete this order:

STEP 1. Obtain the catalog number of the desired IntelliRupter fault interrupter from Table 1 on page 11 and Table 2 on page 12.

Catalog Number: []

STEP 2. Add the suffix of the desired control power source option from Table 3 on page 13.

Suffix: [][][][][]

STEP 3. Add the suffix of the desired control group option from Table 5 on page 15.

Suffix: [][][][]

STEP 4. For 15.5-kV IntelliRupter fault interrupters only: If you would like the interrupters certified and tested to meet 27 kV, then add option “-Z3.”

STEP 5. Add the suffix(es) of desired optional features and special optional features from Tables 6 on page 16 and Table 7 on page 18.

Suffix(es): [][][][][]

STEP 6. If wide-area network capability is desired for the standard control group, standard control group with battery backup, or universal control group, add the suffix of the desired communication device from Table 8 on page 18.

Suffix: [][][][][]

STEP 7. If a mounting pedestal is desired for a substation application, obtain the catalog numbers of the desired mounting pedestal and anchor bolts from Table 10 on page 20. **Note:** Four anchor bolts are required per mounting pedestal.

Catalog Number: [][][][]-[][][][][]-[][]

Catalog Number: [][]-[][][][][][][][]-[][]

STEP 8. Obtain the catalog number of the desired connectors from Table 11 on page 20.

Note: Six connectors are required per IntelliRupter fault interrupter.

Catalog Number: [][][][][][][][]

STEP 9. Obtain the catalog numbers of desired accessories from Table 12 on page 21.

Catalog Number: [][][][]-[][][][][][][][][]-[][][]

Catalog Number: [][][][][]

Catalog Number: [][][][]-[][][][][]

Catalog Number: [][][][]-[][][][][][][][][]

Example: The catalog number for a 27-kV pole-mounted upright-crossarm IntelliRupter PulseCloser Fault Interrupter with a manual disconnect, one integral power module rated for 10.8-15.9 kV (L-L), a standard control with battery backup, arrestors on both sides, and wildlife guards is:

2**4****8****1****2****3****R****1**-**C****1****N****1****P****1****6****2**
W**2**

IntelliRupter® PulseCloser® Fault Interrupter

Anatomy of a IntelliRupter PulseCloser Fault Interrupter

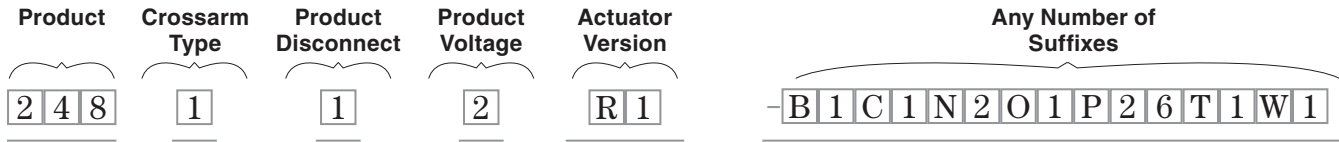

The catalog number created above represents a 15-kV Upright Crossarm IntelliRupter PulseCloser Fault Interrupter, without a manual disconnect. The IntelliRupter fault interrupter requires a control power source option and a control group selection, but all other suffixes are options. This IntelliRupter fault interrupter has a standard control group with a battery backup and two integral power modules fed for different phases rated for 10.8-15.9 kV (L-L). It also has a 10-year warranty and a gray finish.

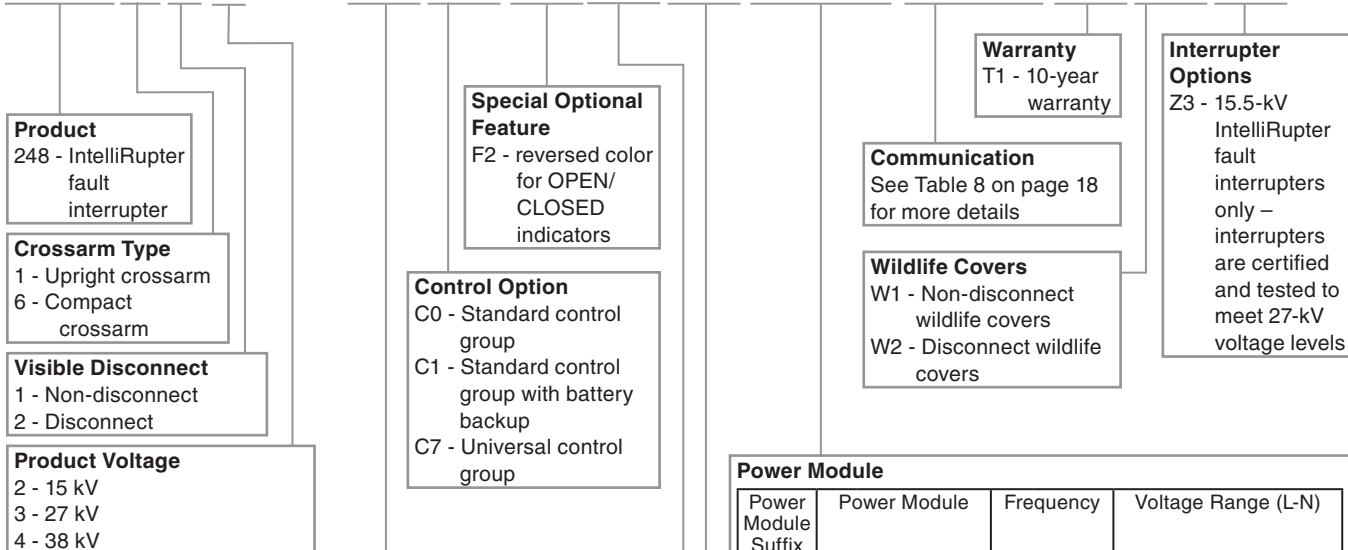

Bracket Mounted Antenna
 B1 - Includes 900-MHz, 3-dBd gain, omnidirectional 25-inch (635-mm) fiberglass antenna with female N-type connector, coaxial cable, and mounting hardware
 B2 - Includes 900-MHz, 9-dBd gain, directional Yagi antenna with female N-type connector, coaxial cable, and mounting hardware
 B3 - Bracket only

Arrestors

Voltage	Suffix	
3-kV, 2.55-kV MCOV	M9	N9
6-kV, 5.1-kV MCOV	M10	N10
9-kV, 7.65-kV MCOV	M1	N1
10-kV, 8.4-kV MCOV	M2	N2
12-kV, 10.2-kV MCOV	M3	N3
15-kV, 12.7-kV MCOV	M4	N4
18-kV, 15.3-kV MCOV	M5	N5
21-kV, 17.0-kV MCOV	M6	N6
24-kV, 19.5-kV MCOV	M7	N7
27-kV, 22.0-kV MCOV	M8	N8
30-kV, 24.0-kV MCOV	-	N11
36-kV, 29.0-kV MCOV	-	N12

M - One arrestor load side, **N** - Two arrestors both sides
MCOV - Maximum Continuous Operating Voltage

Power Module

Power Module Suffix	Power Module	Frequency	Voltage Range (L-N)
P	<input type="checkbox"/>	<input type="checkbox"/>	<input type="checkbox"/>
1	One integral	5 50 Hz	1 50 Hz: 5.7-7.0 kV 60 Hz: 4.3-5.3 kV
2	Two integral	6 60 Hz	2 50 Hz: 7.8-11.3 kV 60 Hz: 6.2-9.2 kV
3	One integral, one external		3 50 Hz: 10.4-15.0 kV 60 Hz: 10.8-15.8 kV
4	Two integral, one external		4 50 Hz: 13.3-19.1 kV 60 Hz: 9.2-12.7 kV
			5 50 Hz: 17.1-21.9 kV 60 Hz: 13.7-21.9 kV

Other Options: P300 = 60-Hz external power supply only, P350 = 50-Hz external power supply only, P000 = Field-installed power source. Choose options from Table 4 on page 14.

Software and Communication Features
 O1 - Advanced Cyber Security Options
 O2 - IEC 60870-5-104 Communication Protocol

Table 1. Non-Disconnect Style IntelliRupter PulseCloser Fault Interrupters^{①②}

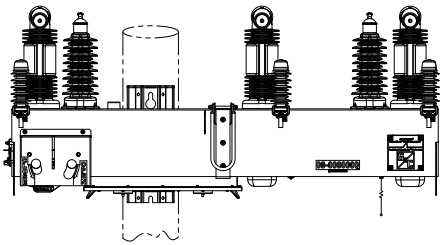
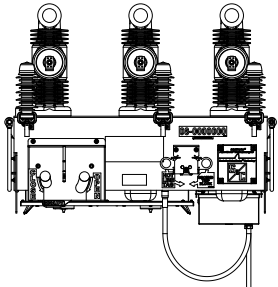
Mounting Configuration	Standard Mounting/ Operating Arrangement ^③	Ratings				Catalog Number ^④
		kV		Amperes, RMS		
		Max	BIL	Cont.	Short-Circuit Breaking and Making Symmetrical	
<p>Upright-Crossarm</p> 	<p>● ● ● ED-856</p>	<p>15.5 27 38</p>	<p>110 125 170</p>	<p>800■ 800■ 630▲</p>	<p>16 000 12 500 12 500</p>	<p>248112R1 248113R1 248114</p>
<p>Compact-Crossarm^⑤</p> 	<p>ED-855 ED-855</p>	<p>15.5 27</p>	<p>110 125</p>	<p>800■</p>	<p>16 000 12 500</p>	<p>248612R1 248613R1</p>

① For adequate power to be available from the integral power module(s), the base of the IntelliRupter fault interrupter must be grounded.

② When applied on a system that is not solidly grounded, uni-grounded, grounded through a grounding transformer, or resonant-grounded through a Petersen coil, total system phase-to-ground capacitance must be sufficient to reduce the neutral-voltage shift produced by the integral power module(s). Refer to the nearest S&C Sales Office.

③ The standard mounting arrangement is designated by the erection drawing (ED) number shown.

④ Includes on-site user training on setup, configuration, and operation of IntelliRupter fault interrupter. This service applies to first-time orders only; it can be provided for subsequent orders as indicated in Table 13 on page 22.

⑤ Requires external power supply, catalog number suffix “-P300” or “-P350.”

● ED-850 for pole mounting, ED-852 for pedestal mounting.

■ Allowable continuous current capability: 900 amperes with a minimum wind velocity of 2 ft./sec.

▲ Allowable continuous current capability: 800 amperes with a minimum wind velocity of 2 ft./sec.

IntelliRupter® PulseCloser® Fault Interrupter

Table 2. Disconnect-Style IntelliRupter PulseCloser Fault Interrupters^{①②}

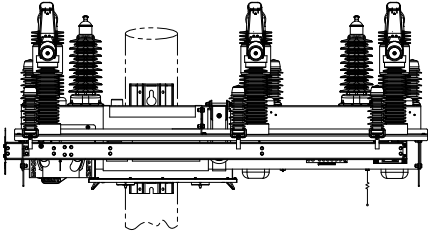
Mounting Configuration	Standard Mounting/ Operating Arrangement ^③	Ratings				Catalog Number ^④
		kV		Amperes, RMS		
		Max	BIL	Cont.	Short-Circuit Breaking and Making Symmetrical	
Upright-Crossarm 	● ● ED-857	15.5 27 38	110 125 170	800■ 800■ 630▲	16 000 12 500 12 500	248122R1 248123R1 248124

① For adequate power to be available from the integral power module(s), the base of the IntelliRupter fault interrupter must be grounded.

② When applied on a system that is not solidly grounded, uni-grounded, grounded through a grounding transformer, or resonant-grounded through a Petersen coil, total system phase-to-ground capacitance must be sufficient to reduce the neutral-voltage shift produced by the integral power module(s). Refer to the nearest S&C Sales Office.

③ The standard mounting arrangement is designated by the erection drawing (ED) number shown.

④ Includes on-site user training on setup, configuration, and operation of IntelliRupter Fault Interrupter. This service applies to first-time orders only; it can be provided for subsequent orders as indicated in Table 13 on page 22.

● ED-851 for pole mounting, ED-853 for pedestal mounting.

■ Allowable continuous current capability: 900 amperes with a minimum wind velocity of 2 ft./sec.

▲ Allowable continuous current capability: 800 amperes with a minimum wind velocity of 2 ft./sec.

Table 3. Control Power Source—One Control Power Source Must Be Specified

Control Power Source		Voltage Range, kV L-N ^①	Overload capability kV L-N for 1.0 min.	Suffix to be Added to	
Integral power modules for use on 60-Hz systems	One integral power module fed from pole 1 on X-side	4.3–5.3	7.5–9.2	-P161	
		6.2–9.2	10.8–15.9	-P162	
		10.8–15.8	18.7–27.4	-P163	
		9.2–12.7	16–22	-P164	
		13.7–21.9	23.8–38	-P165	
	One integral power module fed from pole 1 on X-side plus an external power supply ^②	4.3–5.3	7.5–9.2	-P361	
		6.2–9.2	10.8–15.9	-P362	
		10.8–15.8	18.7–27.4	-P363	
		9.2–12.7	16–22	-P364	
		13.7–21.9	23.8–38	-P365	
	Two integral power modules fed from pole 1 on X-side and from pole 3 on Y-side	4.3–5.3	7.5–9.2	-P261	
		6.2–9.2	10.8–15.9	-P262	
		10.8–15.8	18.7–27.4	-P263	
		9.2–12.7	16–22	-P264	
		13.7–21.9	23.8–38	-P265	
	Two integral power modules fed from pole 1 on X-side and from pole 3 on Y-side plus an external power supply ^②	4.3–5.3	7.5–9.2	-P461	
		6.2–9.2	10.8–15.9	-P462	
		10.8–15.8	18.7–27.4	-P463	
		9.2–12.7	16–22	-P464	
		13.7–21.9	23.8–38	-P465	
External power supply only ^②		—	—	-P300	
Integral power modules for use on 50-Hz systems	One integral power module fed from pole 1 on X-side	5.2–7.0	9.0–12.1	-P151	
		7.8–11.3	13.5–19.6	-P152	
		10.4–15.0	18.0–26.0	-P153	
		13.3–19.1	23.0–33.0	-P154	
		17.1–21.9	29.7–38.0	-P155	
	One integral power module fed from pole 1 on X-side plus an external power supply ^②	5.2–7.0	9.0–12.1	-P351	
		7.8–11.3	13.5–19.6	-P352	
		10.4–15.0	18.0–26.0	-P353	
		13.3–19.1	23.0–33.0	-P354	
		17.1–21.9	29.7–38.0	-P355	
	Two integral power modules fed from pole 1 on X-side and from pole 3 on Y-side	5.2–7.0	9.0–12.1	-P251	
		7.8–11.3	13.5–19.6	-P252	
		10.4–15.0	18.0–26.0	-P253	
		13.3–19.1	23.0–33.0	-P254	
		17.1–21.9	29.7–38.0	-P255	
	Two integral power modules fed from pole 1 on X-side and from pole 3 on Y-side plus an external power supply ^②	5.2–7.0	9.0–12.1	-P451	
		7.8–11.3	13.5–19.6	-P452	
		10.4–15.0	18.0–26.0	-P453	
		13.3–19.1	23.0–33.0	-P454	
		17.1–21.9	29.7–38.0	-P455	
	External power supply only ^②		—	—	-P350
	Field-installed power source—Choose options from Table 4 on page 14.		-P000		

① The voltage range is an absolute value. Operating below the designated lower voltage level may result in the control being unable to function properly. Operating above the upper voltage level may result in damage to the control module.

② The external power supply accepts 90-Vac to 259-Vac, 50/60-Hz, primary source input; and accepts 90-Vac to 259-Vac, 50/60-Hz; 19-Vdc to 60-Vdc; or 100-Vdc to 360-Vdc, secondary source input.

Table 4. Integral Power Modules for field installation

Description	Voltage Range, kV L-N, 50 Hz	Voltage Range, kV L-N, 60 Hz	Catalog Number
Integral power module kit	17.1–21.9	13.7–21.9	SDA-5758-1
Integral power module kit	13.3–19.1	10.8–15.8	SDA-5758-2
Integral power module kit	10.4–15.0	9.2–12.7	SDA-5758-3
Integral power module kit	7.8–11.3	6.2–9.2	SDA-5758-4
Integral power module kit	5.2–7.0	4.3–5.3	SDA-5758-5
External power supply—Use when system voltage is below 4.3 kV (L-N) 60 Hz, 5.2 kV (L-N) 50 Hz, or with a pedestal-mounted IntelliRupter fault Interrupter in a substation. Enables use of preferred and alternate control power sources, and can be installed in combination with integral power modules. Preferred source input voltage range is 90-259 Vac, 50/60 Hz, alternate source input voltage range is 90-259 Vac, 50/60 Hz, 19-60 Vdc, or 100-360 Vdc			SDA-4910

Table 5. Control Groups—One Control Group Must Be Specified

Item	Suffix to be Added to Catalog Number
<p>Standard Control Group—For the IntelliTeam SG Automatic Restoration System, automatic source transfer, automatic loop restoration, SCADA, and stand-alone (non-communicating) applications. Includes IntelliTeam SG Bronze Level Software. Optional IntelliTeam SG Gold Level Software provides suitability for applications on systems with three or more sources.</p> <p>No batteries are required for stand-alone applications and application with operating times of 30 seconds or less; ac line voltage must be available on the side of the IntelliRupter fault interrupter with the integral power module or control power must be available from the external power supply, if furnished.</p> <p>Specify communication device, if required for the application, from Table 8 on page 18. All team devices must be furnished with the same type of communication device.</p> <p>IntelliTeam Designer software is required to activate IntelliTeam SG system software</p>	-C0
<p>Standard Control Group with Battery Backup—Identical to the Standard Control Group but additionally includes batteries that support operation for a minimum of four hours after loss of ac line voltage on both sides of the IntelliRupter fault interrupter, permitting extended dead-line switching.</p> <p>Specify communication device, if required for the application, from Table 8 on page 18. All team devices must be furnished with the same type of communication device.</p> <p>IntelliTeam Designer software is required to activate IntelliTeam SG system software</p>	-C1
<p>Universal Control Group—Identical to the Standard Control Group with Battery Backup. Includes either IntelliTeam SG Gold Level Software and IntelliTeam Designer software or IntelliTeam II Software License, as specified.</p> <p>For IntelliTeam SG Automatic Restoration System specify one IntelliTeam Designer Slot part number 008-007006-01 and one IntelliRupter PulseCloser Fault Interrupter Gold License part number 008-007101-01. This license requires an IntelliTeam SG system-qualified communication device from the communication device options listed in Table 8 on page 18.</p> <p>For IntelliTeam II Automatic Restoration System specify one IntelliTeam Designer Slot part number 008-007006-03● and one IntelliRupter PulseCloser Fault Interrupter IntelliTeam II system license part number 008-007106-01. This license requires an IntelliTeam II system-qualified communication device from the communication device options listed in Table 8 on page 18.</p> <p>When ordering enter the selected licenses as separate line items as included in the above and specify communication device, if required for the application, from Table 8 on page 18. All team devices must be furnished with the same type of communication device</p>	-C7

● The 008-007006-03 license should not be confused with IntelliTeam SG Automatic Restoration System operating in IntelliTeam II mode. An IntelliTeam SG system operating in IntelliTeam II mode requires an IntelliTeam SG system-qualified communication device.

Table 6. Optional Features

Item		Suffix to be Added to Catalog Number
Bracket-mounted antenna—Bracket extends four feet (1219 mm) horizontally from the bottom of IntelliRupter fault interrupter base. Can be mounted on either side of the base①	Includes 900-MHz, 3-dBd gain, omnidirectional 25-inch (635-mm) fiberglass antenna with female N-type connector, coax cable, and mounting hardware	-B1
	Includes 900-MHz, 9-dBd gain, directional Yagi antenna with female N-type connector, coax cable, and mounting hardware	-B2
	Bracket only, suitable for mounting a variety of user-furnished antennas. Includes coax cable with male N-type connector and mounting hardware	-B3
Foreign-language labels and software②	Spanish	-L51
	Portuguese	-L52
	French	-L53
	Chinese	-L54
	Arabic	-L55
International crating—Wood products used in packaging are either hardwood or certified by the wood supplier as being “heat treated” (kiln dried) to a core temperature of 133°F (56°C) for a minimum of 30 minutes. Special fully enclosed crate is available, if needed please add SDA-4796-E to the order		-L71
Shipping crate with increased fork space		-L72
Polymer-housed metal-oxide surge arresters (heavy duty)—factory-installed and wired on the X-side (load) of the compact-style IntelliRupter fault interrupter. Arresters include insulated mounting brackets and integral ground-lead disconnects. Arresters are solidly grounded to IntelliRupter fault interrupter base; a separate ground strap between arresters is not needed③ If the user desires to install their own surge arrester, the IntelliRupter fault interrupter is provided with surge arrester mounting provisions on the X side. In this case, do not choose an “-N” option	3 kV, 2.55 kV MCOV●	-M9
	6 kV, 5.1 kV MCOV●	-M10
	9 kV, 7.65 kV MCOV●	-M1
	10 kV, 8.4 kV MCOV●	-M2
	12 kV, 10.2 kV MCOV●	-M3
	15 kV, 12.7 kV MCOV●	-M4
	18 kV, 15.3 kV MCOV●	-M5
	21 kV, 17.0 kV MCOV●	-M6
24 kV, 19.5 kV MCOV●	-M7	
27 kV, 22.0 kV MCOV●	-M8	

① A whip antenna is not provided when this option is specified. If a whip antenna is needed for testing or temporary use, specify catalog number 904-000071-00.

② All labels are available. Contact the nearest S&C Sales Office for software availability

③ The “-M” option suffixes are only used with compact-style units catalog numbers 248612R1 and 248613R1. Compact-style units rely on the substation bus for protection on the X side, and the “-M” option suffix only provides arresters on the load side.

● MCOV=maximum continuous operating voltage, RMS. MCOV must be $\geq 1.2 \times$ actual line-to-ground voltage, RMS.

TABLE CONTINUED ►

Item		Suffix to be Added to Catalog Number
Polymer-housed metal-oxide surge arresters (heavy duty)—factory-installed and wired on both sides of the IntelliRupter fault interrupter. Arresters include insulated mounting brackets and integral ground-lead disconnects. Arresters are solidly grounded to IntelliRupter fault interrupter base; a separate ground strap between arresters is not needed ^④ If user desires to install their own surge arrester, the IntelliRupter fault interrupter is provided with surge arrester mounting provisions on both sides. In this case, do not choose an “-M” option	3 kV, 2.55 kV MCOV●	-N9
	6 kV, 5.1 kV MCOV●	-N10
	9 kV, 7.65 kV MCOV●	-N1
	10 kV, 8.4 kV MCOV●	-N2
	12 kV, 10.2 kV MCOV●	-N3
	15 kV, 12.7 kV MCOV●	-N4
	18 kV, 15.3 kV MCOV●	-N5
	21 kV, 17.0 kV MCOV●	-N6
	24 kV, 19.5 kV MCOV●	-N7
	27 kV, 22.0 kV MCOV●	-N8
	30 kV, 24.0 kV MCOV●	-N11
	36 kV, 29.0 kV MCOV●	-N12
Optional software and communication features	Advanced cyber security options	-O1
	IEC 60870-5-104 communication protocol	-O2
Ten-year IntelliRupter fault interrupter warranty—In lieu of standard two-year warranty. Matches standard 10-year warranty for control groups		-T1
Wildlife protection	For non-disconnect style IntelliRupter fault interrupter	-W1
	For disconnect-style IntelliRupter fault interrupter	-W2
Interrupter options	15.5-kV IntelliRupter fault interrupter furnished with interrupters tested and certified to meet 27 kV ratings	

④ The “-N” option suffixes are not used with compact-style units Catalog Numbers 248612R1 and 248613R1.

● MCOV=maximum continuous operating voltage, RMS. MCOV must be $\geq 1.2 \times$ actual line-to-ground voltage, RMS.

Table 7. Special Optional Feature

Item	Suffix to be Added to Catalog Number
Reversed colors for interrupter OPEN/CLOSED indicators and OPEN/CLOSE/READY lever (green for closed, red for open)	-F2

Table 8. Communication Devices for IntelliTeam SG System, IntelliTeam II System, Automatic Source Transfer, and SCADA Applications

Item	Suffix to be Added to Catalog Number
Communication devices suitable for IntelliTeam SG system, IntelliTeam II system, automatic source transfer, and SCADA applications①	
Factory-installed and wired iS5 Comm. Inc. - iES6 module with 2-SFP 100-Mbps multi-mode LC transceiver 550 m, 850 nm, low-voltage (input 9-36 Vdc)②	-R278
Factory-installed and wired iS5 Comm. Inc. - iES6 module with 2-SFP 100-Mbps multi-mode LC transceiver 2 km, 1310 nm, low-voltage (input 9-36 Vdc)②	-R279
Factory-installed and wired iS5 Comm. Inc. - iES6 module with 2-SFP 100-Mbps single mode LC transceiver 20 km, 1310 nm, low-voltage (input 9-36 Vdc)②	-R280
Factory-installed and wired iS5 Comm. Inc. - iES6 module with 2-SFP 100-Mbps single mode LC transceiver 30 km, 1310 nm, low-voltage (input 9-36 Vdc)②	-R281
Factory-installed and wired iS5 Comm. Inc. - iES6 module with 2-SFP 100-Mbps single mode LC transceiver 60 km, 1310 nm, low-voltage (input 9-36 Vdc)②	-R282
Factory-installed and wired iS5 Comm. Inc. - iES6 module with 2-SFP 100-Mbps single mode LC transceiver 100 km, 1550 nm, low-voltage (input 9-36 Vdc)②	-R283
Factory-installed and wired iS5 Comm. Inc. - iES6 module with 2-SFP 100-Mbps single mode LC transceiver 120 km, 1550 nm, low-voltage (input 9-36 Vdc)②	-R284
Provision only for iS5 Comm. Inc. - iES6 module – multimode LC transceiver use - Customer must provide an iES6 module with 2-SFP LC transceivers.	-R276
Provision only for iS5 Comm. Inc. - iES6 module – single-mode LC transceiver use - Customer must provide an iES6 module with 2-SFP LC transceivers.	-R277
Provision only for Itron Bridge 5 (Gen 5) radio - Customer must provide/install Itron Bridge 5 radio	-R401
Communication devices suitable for IntelliTeam II system, automatic source transfer, and SCADA applications①	
Provisions for Landis+Gyr Series 5 Network Integrated WanGate Radio (IWR)	-R399
Communication devices suitable for automatic source transfer and SCADA applications only	
Factory-installed and wired SpeedNet™ Cell Edge Gateway 4G LTE Cellular Modem with removable SIM card for USA and Canada (shipped without SIM card)③	-R352
Provision only for single-mode Dymec 5843SHRT fiber-optic modem⑤	-R42
Provision only for multi-mode Dymec 5843HRT fiber-optic modem④	-R43
Factory-installed and wired MDS SD9 Radio	●
Factory-installed and wired MDS TransNET 900 transceiver and 900-MHz, 5-dBi gain antenna with male N-type connector⑥⑦	-R18
Factory-installed and wired MDS TransNET 900 transceiver with diagnostics and 900-MHz, 5-dBi gain antenna with male N-Type connector⑥⑦	-R19

FOOTNOTES FOR THIS TABLE ARE ON PAGE 19. ►

FOOTNOTES FOR TABLE 8

- ① These are the only wide-area network communication devices approved for use with IntelliRupter fault interrupter. For other communication devices, refer to the nearest S&C Sales Office.
- ② When using these devices with an IntelliRupter fault interrupter, the connector provided is an SC type.
- ③ Please see Specification Bulletin 1076-31 for SpeedNet Cell Edge Gateway antenna options.
- ④ A multi-mode mating connector and termination kit or a multi-mode liquid-tight cable assembly must be specified. See Table 9 on page 20.
- ⑤ A single-mode mating connector and termination kit or a single-mode liquid-tight cable assembly must be specified. See Table 9 on page 20.
- ⑥ Antenna mounts directly to IntelliRupter fault interrupter base. If a bracket-mounted antenna is desired instead, see Table 6 on page 16.
- ⑦ A female N-type antenna connector, with integral surge suppressor, is mounted to IntelliRupter fault interrupter base.
- Specify the appropriate catalog number suffix based on the frequency band range and application for the radio, from the following table. For example, for a 928- to 960-MHz MDS SD9 Radio for Ethernet and serial application, specify catalog number suffix “-R216CL.”

Frequency Band Range, MHz	Application	Suffix to be Added to Catalog Number
820 to 870	Serial	-R216AK
928 to 960		-R216CK
928 to 960, 50-kHz Channel		-R216DK
880 to 915		-R216EK
880 to 915, 50-kHz Channel		-R216FK
850 to 860 / 926 to 936, Transmit Low		-R216GK
850 to 860 / 926 to 936, Transmit High		-R216HK

Frequency Band Range, MHz	Application	Suffix to be Added to Catalog Number
820 to 870	Ethernet and Serial	-R216AL
928 to 960		-R216CL
928 to 960, 50-kHz Channel		-R216DL
880 to 915		-R216EL
880 to 915, 50-kHz Channel		-R216FL
850 to 860 / 926 to 936, Transmit Low		-R216GL
850 to 860 / 926 to 936, Transmit High	-R216HL	
820 to 870	9710 Emulation	-R216AM
928 to 960		-R216CM
928 to 960, 50-kHz Channel		-R216DM
880 to 915		-R216EM
880 to 915, 50-kHz Channel		-R216FM
850 to 860 / 926 to 936, Transmit Low		-R216GM
850 to 860 / 926 to 936, Transmit High		-R216HM

Table 9. Fiber-Optic Connection Accessories

Item	Catalog Number
Single-mode mating connector and termination kit—Includes connector hood, inserts, and fiber termination components①	SD-6607
Multi-mode mating connector and termination kit—Includes connector hood, inserts, and fiber termination components①	SD-6608
48-foot (1463-cm) single-mode liquid-tight cable assembly—Includes pre-terminated mating connector on one end and ST connector on other end②	SD-6609
48-foot (1463-cm) multi-mode liquid-tight cable assembly—Includes pre-terminated mating connector on one end and ST connector on other end②	SD-6610

① Requires Harting crimping tool for fiber-optic connector (glass fiber) SW 6.5, 4.95, and 3.0 mm, catalog number 20 99 000 1033.

② Custom-length cable assemblies can be furnished. Refer to the nearest S&C Sales Office for more information.

Table 10. Mounting Pedestals and Anchor Bolts—For Substation Applications

Item	Catalog Number	
Mounting pedestal—8-inch × 8-inch (203 mm × 203 mm) galvanized steel tube construction	9.5 feet (2896 mm)	SDA-4813-1
	12 feet (3658 mm)	SDA-4813-2
Anchor bolt①—1 pcs 1¼–7 UNC-2A, 3 feet-8 inches (1118 mm). Four (4) required per mounting pedestal	S-81365-1	

① Quantity of 4 needed for each pedestal. Material galvanized steel. Furnished with two hex nuts and two flat washers to facilitate leveling the mounting pedestal.

Table 11. Connectors

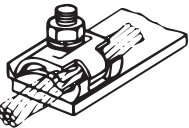
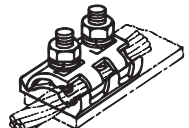
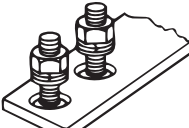
Illustration	Description	Accommodating Conductor	Catalog Number
	Bronze body, tin-plated, single ½–13 × 2½ galvanized steel bolt	No. 2 solid (33.6 mm²) through 500 kc mil (335 mm²) stranded copper or aluminum	4740R1●■
	Aluminum-alloy body, tin-plated, two ½–13 × 2¾ galvanized steel bolts	No. 2 solid (33.6 mm²) through 500 kc mil (335 mm²) stranded copper or aluminum	4741R2●▲
	Provision only for compression connectors. Includes two ½–13 × 2 galvanized steel bolts		4581●◆

- Connector suitable for hookstick handling.
- This item cannot be used with 38-kV models.
- ▲ Use this item with 38-kV models.
- ◆ Four-bolt compression connectors cannot be used with wildlife protection, catalog number suffix “-W1” or “-W2.”

Table 12. Accessories

Description	Catalog Number
Battery charger output harness—For connecting battery pack to an 800-mA, current-limited 12-Vdc lead-acid battery charger	007-001551-02
Module handling fitting—For field installation and removal of protection and control module, and communication module, in IntelliRupter fault interrupter base. Attaches to hookstick with universal fitting. Includes prong for operating IntelliRupter fault interrupter levers	4450
Module stub handle—For installation and removal of protection and control module, and communication module, in IntelliRupter fault interrupter base—in user's service center or lab. When permitted by utility operating practice, this handle can be used by a gloved individual to install and remove modules in the field	4435
15-kV and 27-kV upright-crossarm IntelliRupter fault interrupter information package	RD-6948
Spare protection and control module (R3 Control Module)	SDA-4540R3
Protection and control module with external interface port	SDA-5799
Spare communication module—Less battery pack and radio	SDA-4554R3-1
Spare 12-Vdc, 8-ampere-hour battery pack for communication module	SDA-4605
Docking station—Powers protection and control module, and communication module, removed from IntelliRupter fault interrupter base. Permits uploading and downloading of configuration settings, plus programming of radio and charging of radio batteries, as applicable, in user's service center or lab	SDA-4650R3
Indoor power supply—Attaches to external power supply connector in base. Powers protection and control module, and communication module, for pre-installation uploading and downloading of configuration settings, plus radio programming and battery charging, as applicable. For indoor use only, in user's service center or lab. Input voltage range is 88–264 Vac, 50/60 Hz	TA-3221
900-MHz 5-dBi gain antenna, N-type male connector	904-000071-00
LinkStart security dongle	904-002216-01
iS5 Comm. Inc. - iES6 module only with conformal coating, power terminal block and DB9 console cable, low-voltage 9-36 Vdc, LC connector	110-003780-01
SFP 100-Mbps multi-mode LC transceiver 550 m, 850 nm	110-003774-01
SFP 100-Mbps multi-mode LC transceiver 2 km, 1310 nm	110-003774-02
SFP 100-Mbps single-mode LC transceiver 20 km, 1310 nm	110-003774-04
SFP 100-Mbps single-mode LC transceiver 30 km, 1310 nm	110-003774-05
SFP 100-Mbps single-mode LC transceiver 60 km, 1310 nm	110-003774-06
SFP 100-Mbps single-mode LC transceiver 100 km, 1550 nm	110-003774-07
SFP 100-Mbps single-mode LC transceiver 120 km, 1550 nm	110-003774-08
iS5 Comm. Inc. – iES22GF industrial Ethernet switch, high voltage (input 130-370 Vdc or 90-264 Vac), 8-10/100/1000 base TX RJ45 ports, 4 - GSFP	110-003777-01
iS5 Comm. Inc. – iES22GF industrial Ethernet switch, low-voltage (input 9-36 Vdc), 8-10/100/1000 base TX RJ45 ports, 4 - GSFP	110-003778-01
iS5 Comm. Inc. – iDS3 industrial single port RS232/422/485 to Ethernet serial device server, low-voltage (input 9-36 Vdc), 1-serial port, 2-10/100 base TX RJ45 Ports	110-003779-01

Table 13. IntelliRupter Fault Interrupter Services Packages

Item	Catalog Number
Communication site survey. Field testing to confirm that user-proposed IntelliRupter fault interrupter locations will provide acceptable communication between team members and head-end SCADA radio, if applicable. User should make available the engineer/technician responsible for the project	AS100
IntelliTeam SG system training. On-site training on functioning of the IntelliTeam SG Automatic Restoration System. Includes operations and engineering training sessions	AS101
IntelliTeam SG system commissioning. Ensures that IntelliRupter fault interrupters have been set up correctly and the IntelliTeam SG system is ready to be put into service	AS102
IntelliTeam SG system SCADA integration. Includes review of user's SCADA system, development of DNP points lists, coordination with the user's SCADA supplier, and review of SCADA database	AS103
IntelliTeam SG system factory-acceptance testing. Factory testing ensures that all information required for successful IntelliTeam SG system implementation is gathered and understood prior to commissioning. Provides insight on how the IntelliTeam SG Automatic Restoration System will work on the user's system. User must travel to Chicago to witness the testing	AS104
IntelliTeam SG system monitoring. Ongoing remote monitoring ensures the IntelliTeam SG system operation meets agreed-upon service levels. Minimum monitoring period is six months	AS105
IntelliRupter fault interrupter maintenance. Includes inspection, testing, and battery replacement on a three-year interval	AS106
IntelliRupter fault interrupter project and construction management. Includes IntelliRupter fault interrupter installation, construction oversight, and EPC projects	AS107
Overcurrent protective device coordination study. Determination of appropriately rated protective devices and their settings, including those of IntelliRupter fault interrupters. Proper coordination minimizes the impact of short-circuits, by isolating faults as quickly as possible, while maintaining power to the rest of the system	AS108
IntelliTeam SG system device settings determination. Determination of these settings is essential to the successful implementation of the IntelliTeam SG system and must be documented before factory acceptance testing and commissioning	AS109
Loop-restoration training. Covers setup, configuration, and operation of IntelliRupter fault interrupters in a loop application comprised of normally closed IntelliRupter fault interrupters or conventional reclosers, with a normally open IntelliRupter fault interrupter switching point	AS110
IntelliRupter fault interrupter training. Covers IntelliLink Setup Software; configuring IntelliRupter fault interrupter for use in an IntelliTeam SG system, source-transfer, or loop-restoration system, as appropriate; use of security keys; and operation	AS111
IntelliRupter fault interrupter secondary injection testing. Validates settings, functions, and logic of IntelliRupter fault interrupter protection and control module using Omicron testing equipment	AS112

IntelliRupter Fault Interrupter Ratings

Table 14. Voltage Ratings

Voltage Rating	IntelliRupter Fault Interrupter Maximum Voltage Rating, kV		
	15.5	27	38
Lightning impulse withstand voltage, kV	110	125	170
Power frequency withstand voltage, dry, kV	50	60	70
Power frequency withstand voltage, wet, kV	45	50	60

Table 15. Current Ratings

Current Rating	IntelliRupter Fault Interrupter Maximum Voltage Rating, kV		
	15.5	27	38
Continuous current for disconnect and non-disconnect models, amperes	800	800	630
Maximum continuous current with 2 ft./sec. minimum wind velocity, amperes	900	900	800
Short-circuit breaking and making symmetrical	16 000	12 500	12 500
Loop-switching current, amperes	2 400	2 400	2 400
Line-charging current, amperes	2	5	5
Cable charging current, amperes	10	25	40

Table 16. Number of Operations

Operations Rating		IntelliRupter Fault Interrupter Maximum Voltage Rating, kV		
		15.5	27	38
Number of operations at percent of interrupting rating	15–20	44	44	44
	45–55	56	56	56
	90–100	16	16	16
Number of load-switching operations, C-O		10	10	10
Number of line-charging operations, C-O		20	20	20
Number of cable-charging operations, C-O		20	20	20
Number of mechanical operations without maintenance, PulseClosing Technology disabled		10 000	10 000	2 000

Table 17. Other Ratings

Rating	IntelliRupter Fault Interrupter Maximum Voltage Rating, kV		
	15.5	27	38
Operating temperature range, °C (°F)	-40 (-40) to +50 (122)	-40 (-40) to +50 (122)	-40 (-40) to +50 (122)
Voltage sensor accuracy, %	±0.5	±0.5	±0.5
Current sensor accuracy, %	±0.5	±0.5	±0.5
Time-current coordination curve accuracy, %	±2.0	±2.0	±2.0
Ice breaking rating, inch (mm)	0.75 (19)	0.75 (19)	0.75 (19)
Radio noise limit, FCC class	A	A	A

Table 18. IntelliRupter Fault Interrupter Certified Test Abstracts and Engineering Test Reports

Description	Description	Standard
CERT-1325	Temperature rise ratings, 15.5 kV and 27 kV	IEEE C37.60-2003, IEC 62271-111:2005
CERT-1078	Dielectric ratings, 15.5 kV and 27 kV	IEEE C37.60-2003, IEC 62271-111:2005, IEEE C37.34-1994, IEEE 1291-1993, ANSI C93.1-1999
CERT-1055	Short-time and peak-withstand current, fault interrupting, and line- and cable-charging switching tests, 15.5 kV and 27 kV	IEEE C37.60-2012, IEC 62271-111:2012
CERT-1058	Mechanical endurance ratings, 15.5 kV and 27 kV	IEEE C37.60-2012, IEC 62271-111:2007
CERT-705	Loop switching capability, 15.5 kV and 27 kV	IEEE C37.60-2003, IEC 62271-111:2005
CERT-706	Extreme ambient temperature, 15.5 kV and 27 kV	IEEE C37.60-2003
CERT-719	Surge immunity ratings, 15.5 kV, 27 kV and 38 kV	IEEE C37.60-2003, IEEE C37.90-1989, IEEE C37.90.2-2004, IEC 61000-4-4, -4, FCC Part 15, Subpart B, Section 15.109b
CERT-722	Lightning arrester grounding, 15 kV, 27 kV and 38 kV	IEEE C37.60-2003
CERT-766	Voltage and current metering accuracy, 15 kV, 27 kV and 38 kV	IEEE C37.60-2003, IEEE C57.13
CERT-896	Short-time and peak withstand current, fault interrupting, and line- and cable-charging switching tests, 38 kV	IEEE C37.60-2012, IEC 62271-111:2012-09
CERT-897	Temperature rise ratings, 38 kV	IEEE C37.60-2012, IEC 62271-111:2012-09
CERT-898	Dielectric ratings, 38 kV	IEEE C37.60-2012, IEC 62271-111:2012-09
CERT-900	Mechanical endurance ratings, 38 kV	IEEE C37.60-2012, IEC 62271-111:2012-09
CERT-1215	220% Open VI-applied voltage tests, 15 and 27 kV	N/A
CERT-1216	220% Open VI-applied voltage tests, 15 and 27 kV	N/A

Terminal Pad Detail 15-kV and 27-kV Non-Disconnect Style IntelliRupter Fault Interrupter
 (shown without optional wildlife protection, catalog number suffix “-W1”)

Dimensions in inches (mm)

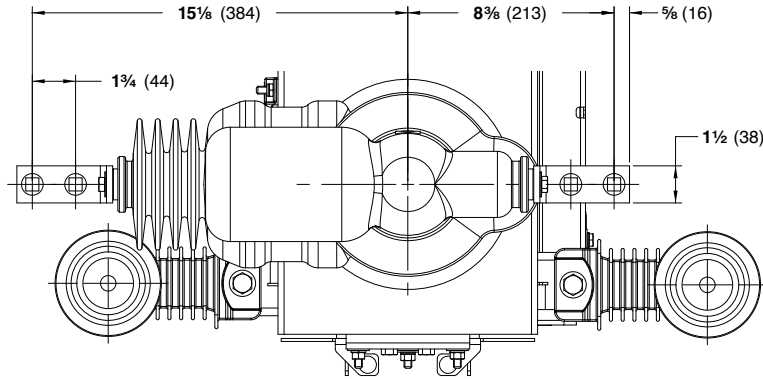

Terminal Pad Detail 38-kV Non-Disconnect Style IntelliRupter Fault Interrupter
 (shown without optional wildlife protection, catalog number suffix “-W1”)

Dimensions in inches (mm)

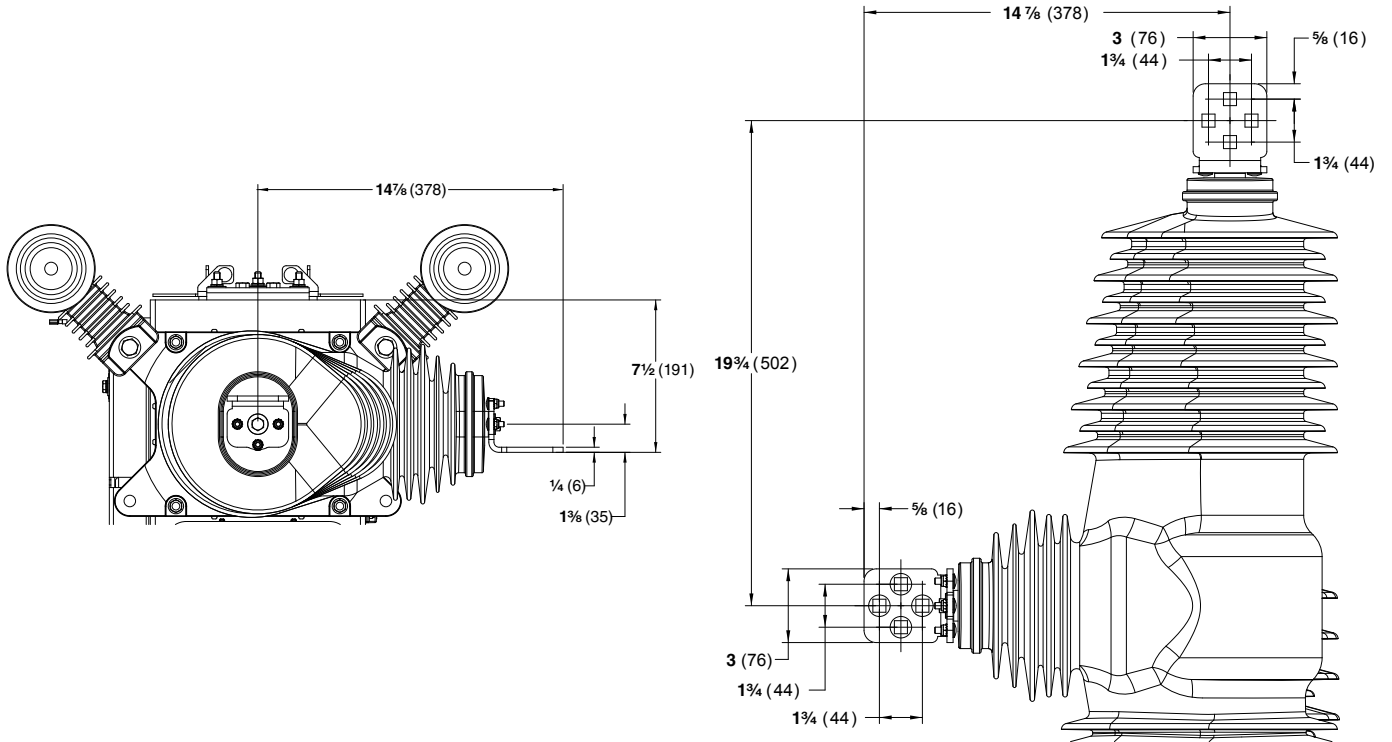

Terminal Pad Detail 15-kV and 27-kV Disconnect-Style IntelliRupter Fault Interrupter
(shown without optional wildlife protection, catalog number suffix “-W2”)

Dimensions in inches (mm)

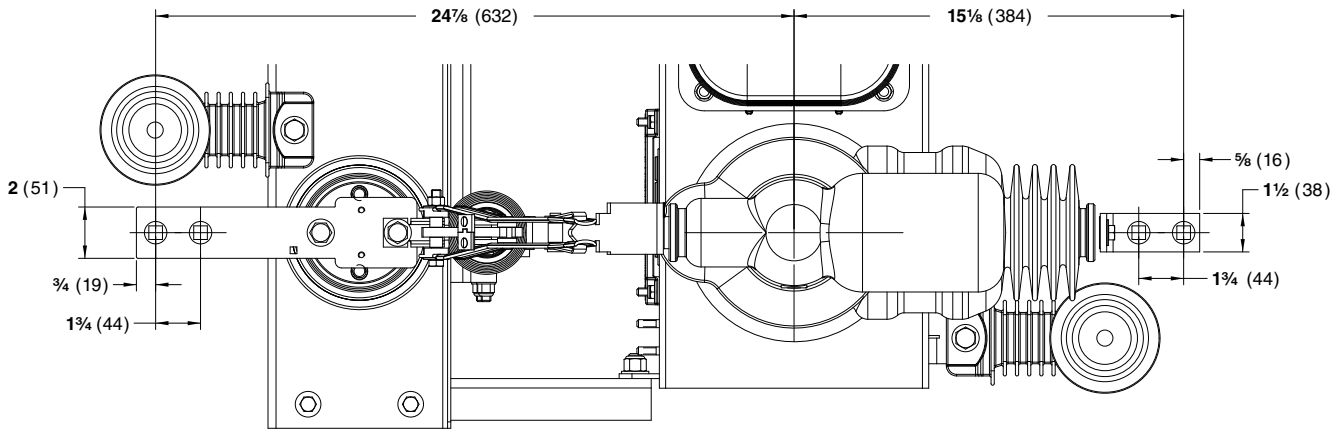

Terminal Pad Detail 38-kV Disconnect-Style IntelliRupter Fault Interrupter
(shown without optional wildlife protection, catalog number suffix “-W2”)

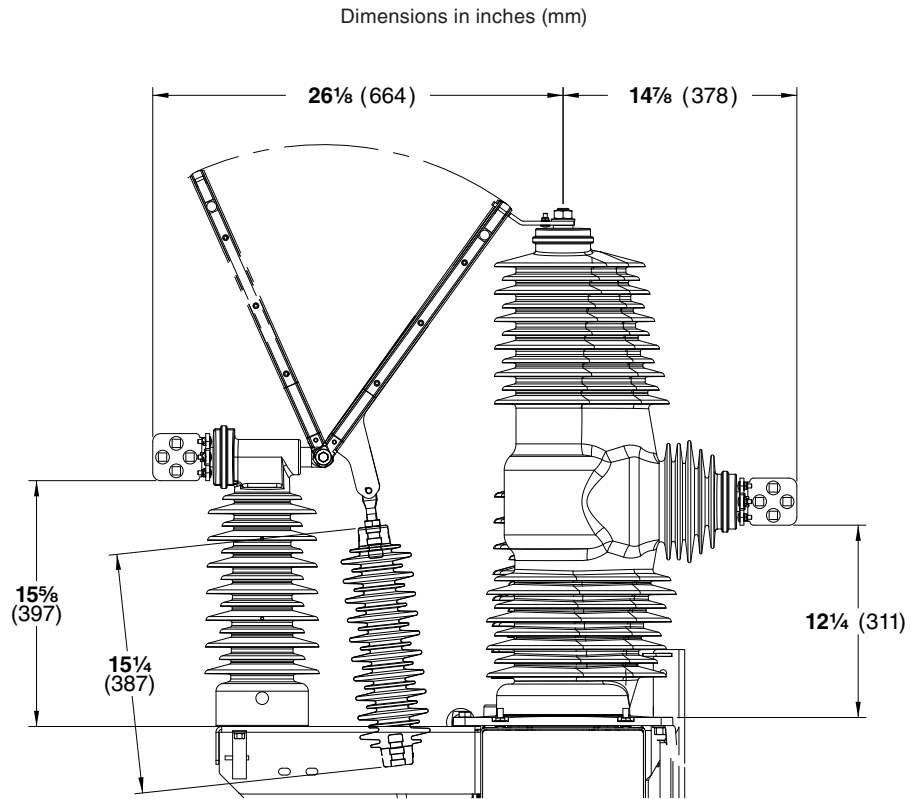

IntelliRupter® PulseCloser® Fault Interrupter

Non-Disconnect Style 15-kV and 27-kV IntelliRupter Fault Interrupter

Upright-Crossarm Mounting Configuration

ED-850, for pole mounting, is illustrated; ED-852, for pedestal mounting, is similar

(top and front views shown with optional wildlife protection, catalog number suffix “-W1”)

Dimensions in inches (mm)

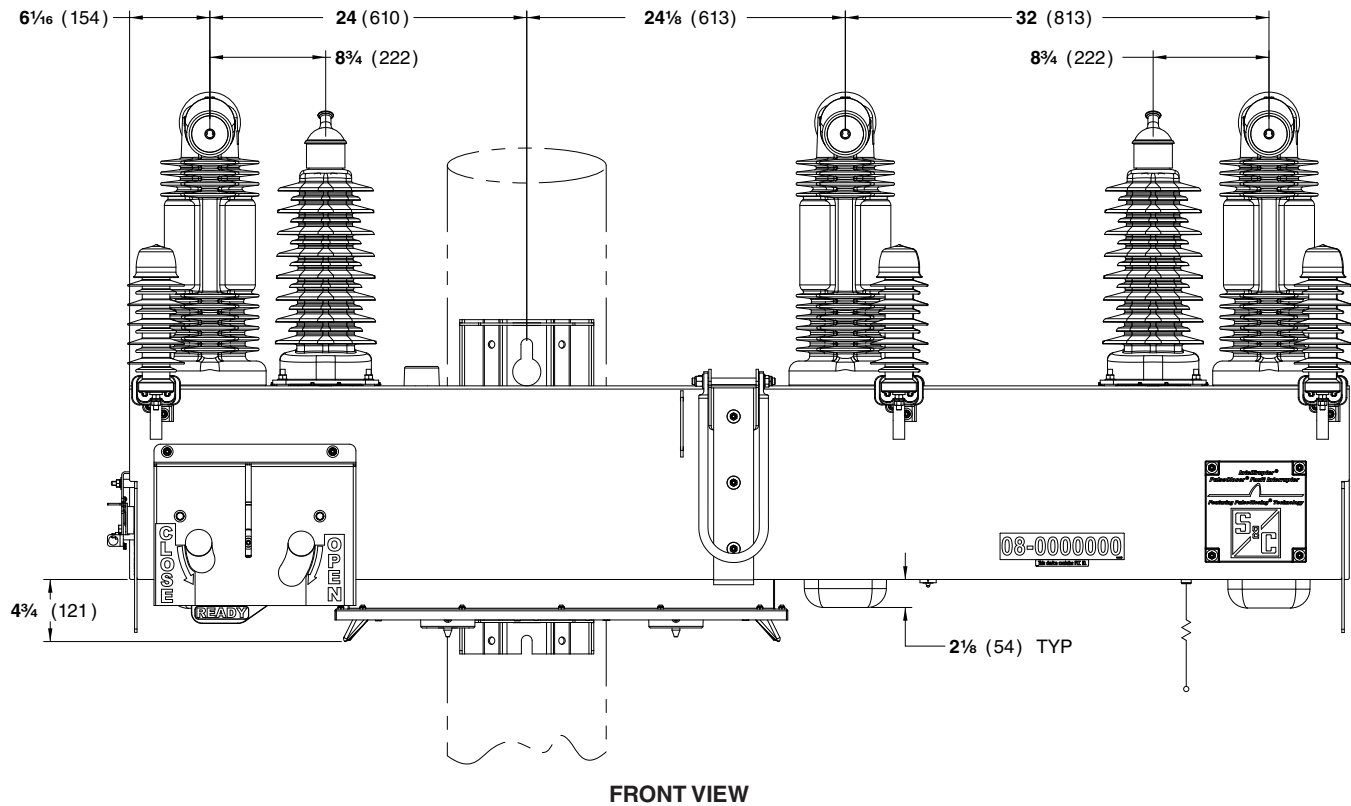

IntelliRupter® PulseCloser® Fault Interrupter

Dimensions in inches (mm)

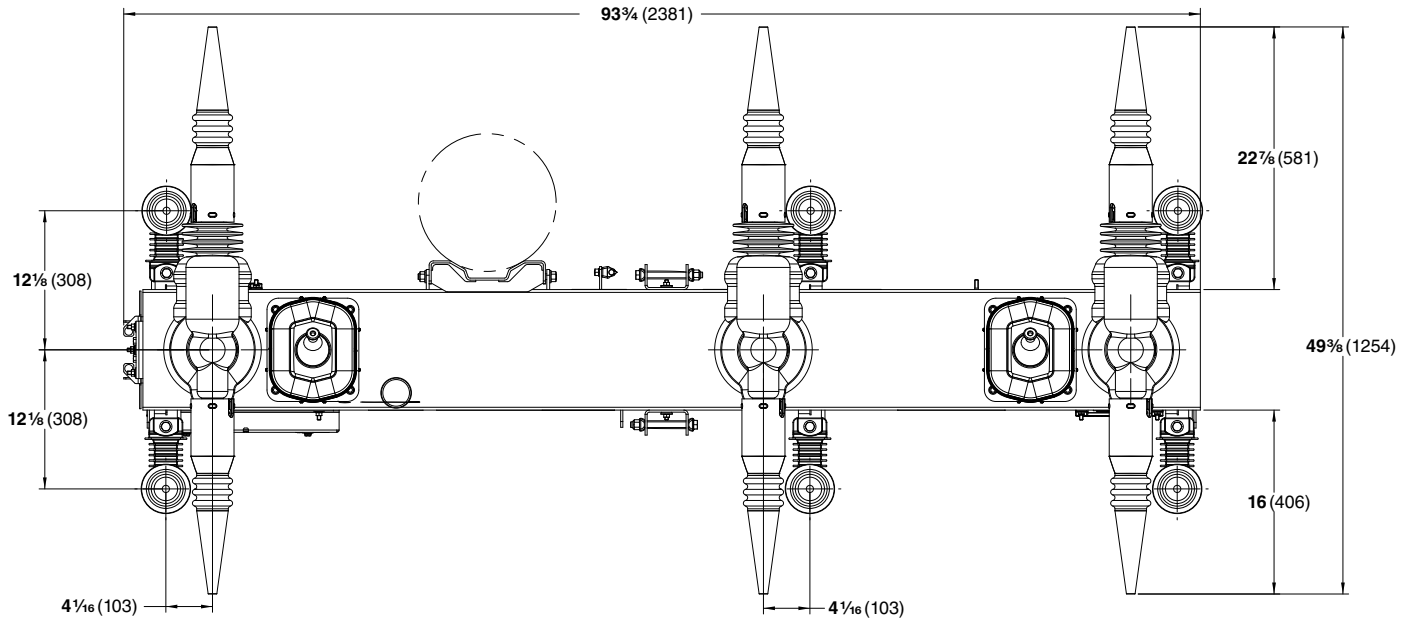

TOP VIEW

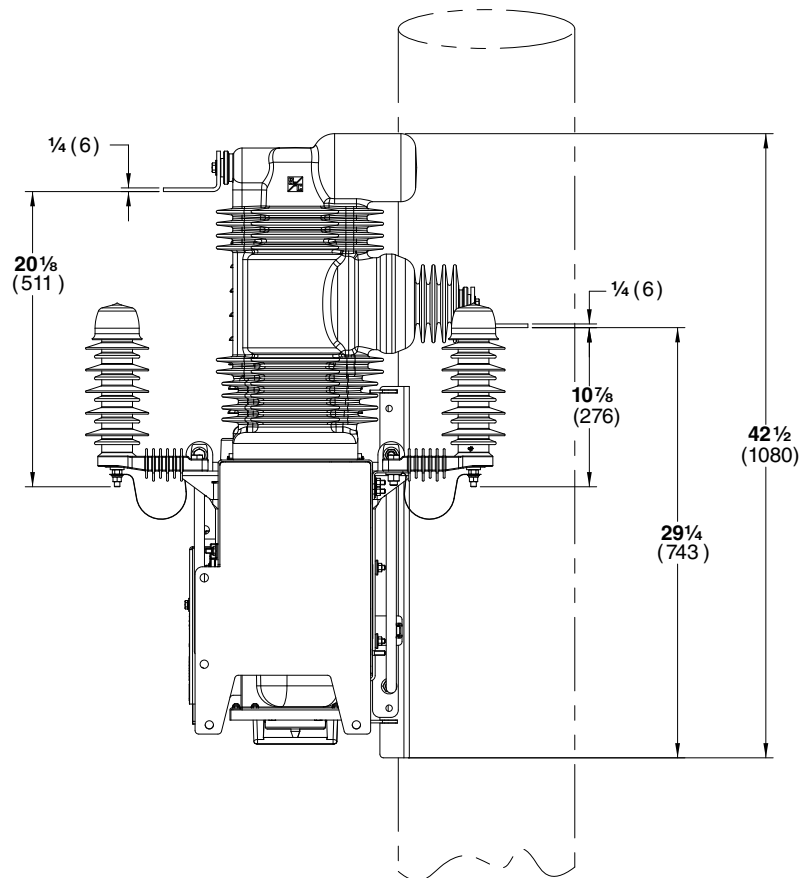

SIDE VIEW

**Non-Disconnect Style 38-kV IntelliRupter Fault Interrupter
Upright-Crossarm Mounting Configuration, ED-856**

(top and front views shown without optional wildlife protection, catalog number suffix “-W1”)

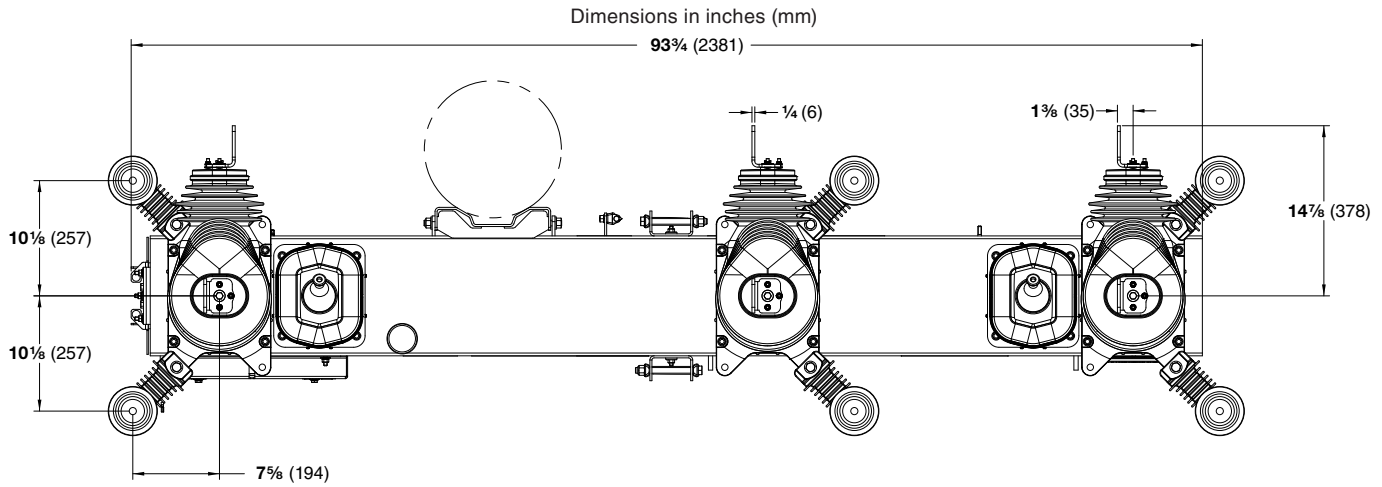

TOP VIEW

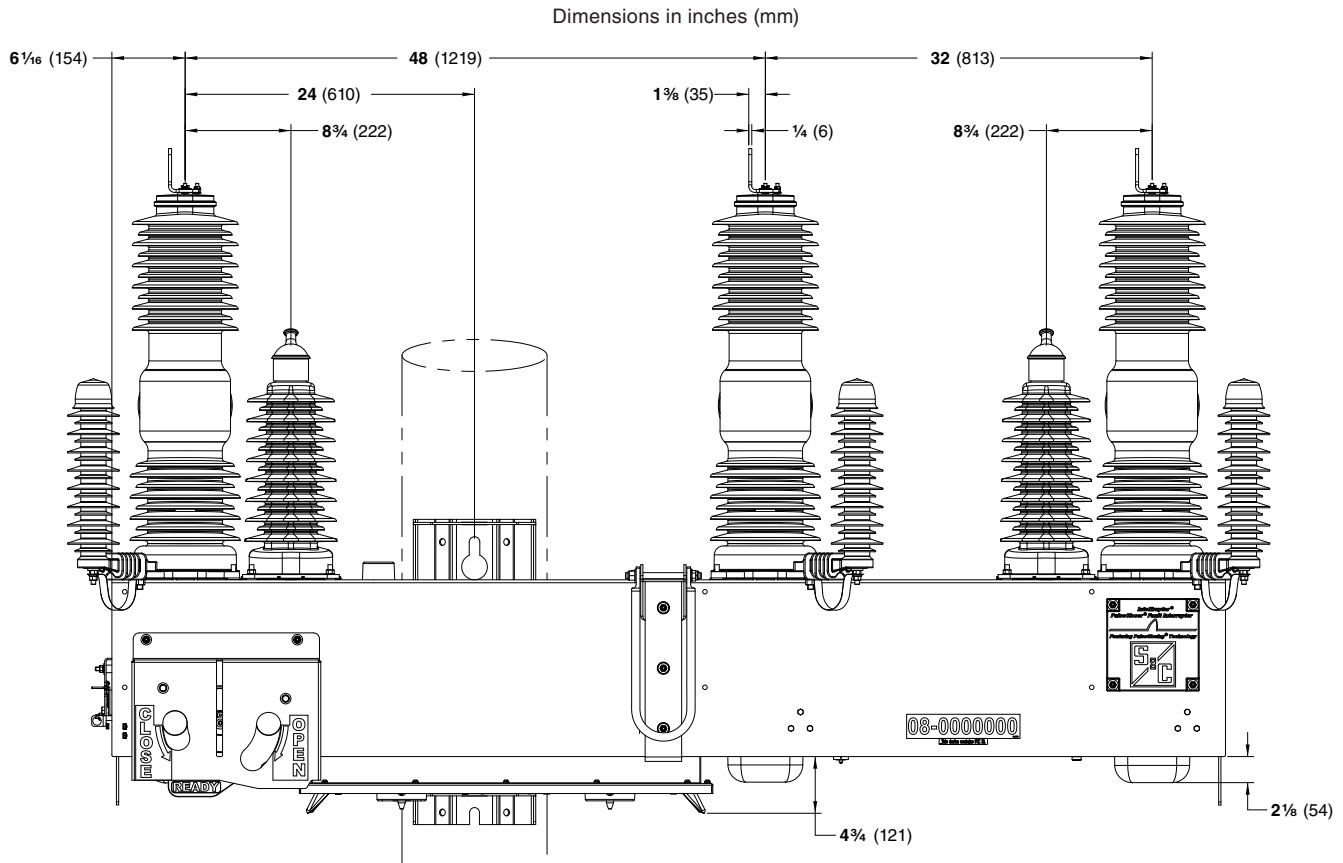

FRONT VIEW

Dimensions in inches (mm)

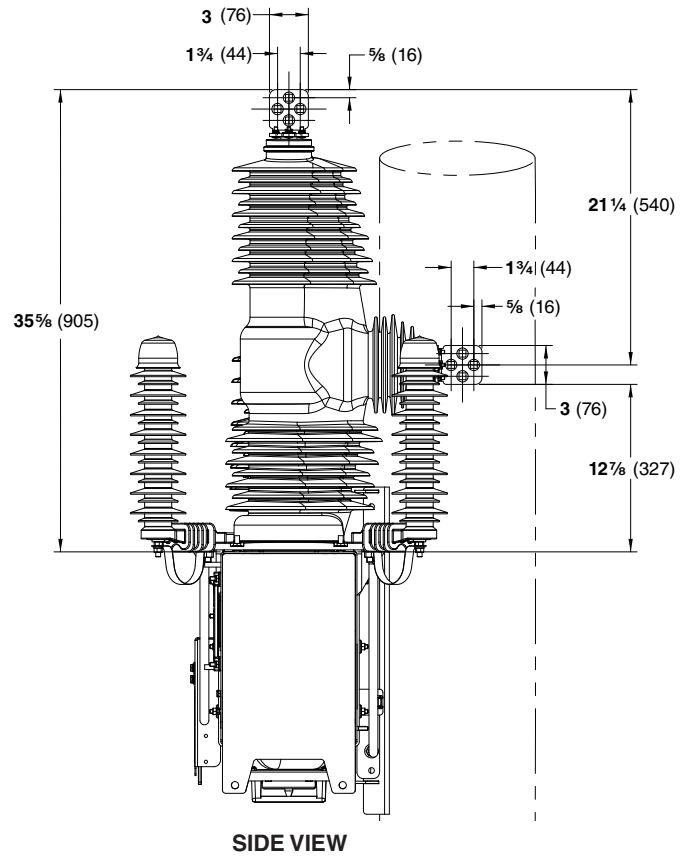

IntelliRupter® PulseCloser® Fault Interrupter

Non-Disconnect Style 15-kV and 25-kV IntelliRupter Fault Interrupter

Compact-Crossarm Mounting Configuration, ED-855

(top and front views shown with optional wildlife protection, catalog number suffix “-W1”)

Dimensions in inches (mm)

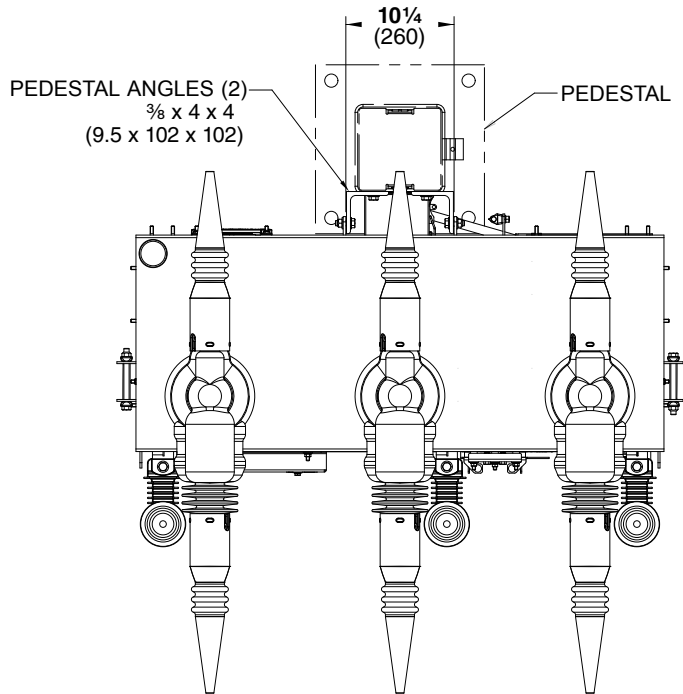

TOP VIEW

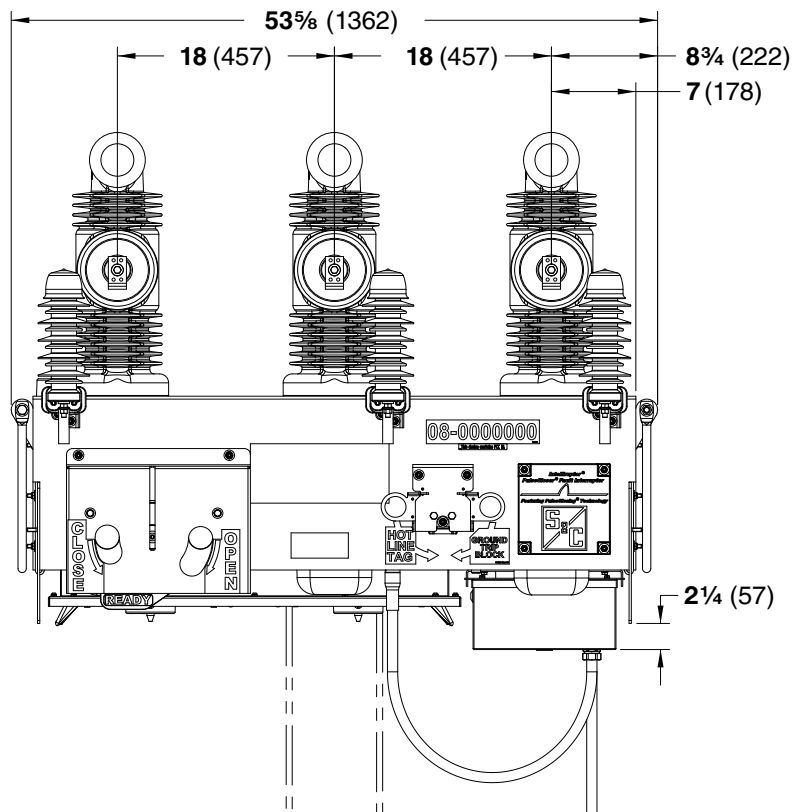

FRONT VIEW

Dimensions in inches (mm)

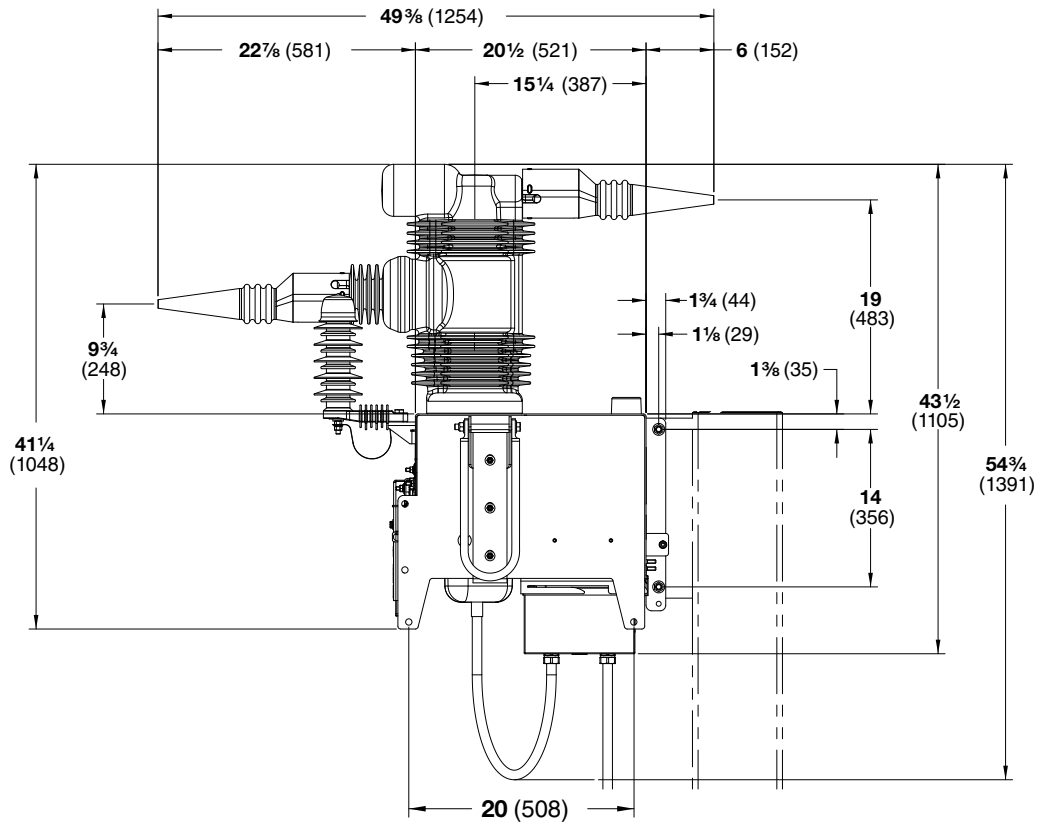

SIDE VIEW

IntelliRupter® PulseCloser® Fault Interrupter

Disconnect-Style 15-kV and 27-kV IntelliRupter Fault Interrupter

Upright-Crossarm Mounting Configuration

ED-851, for pole-mounting, is illustrated; ED-853, for pedestal mounting, is similar

(top and front views shown with optional wildlife protection, catalog number suffix “-W2”)

Dimensions in inches (mm)

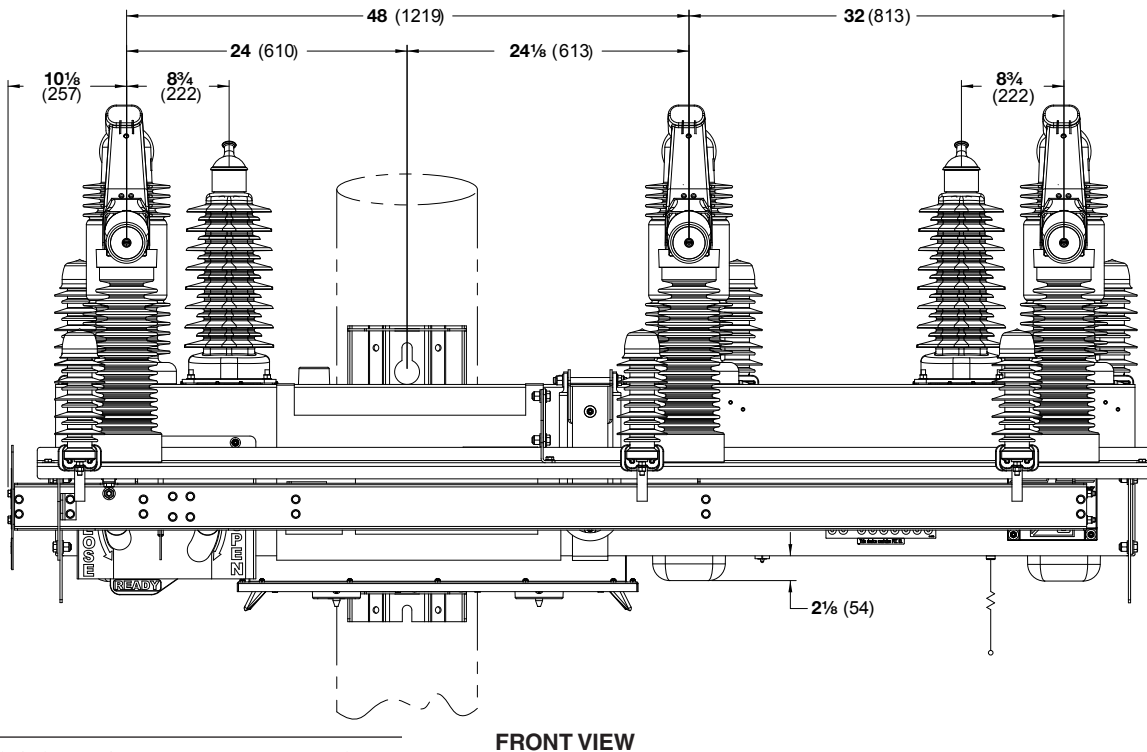
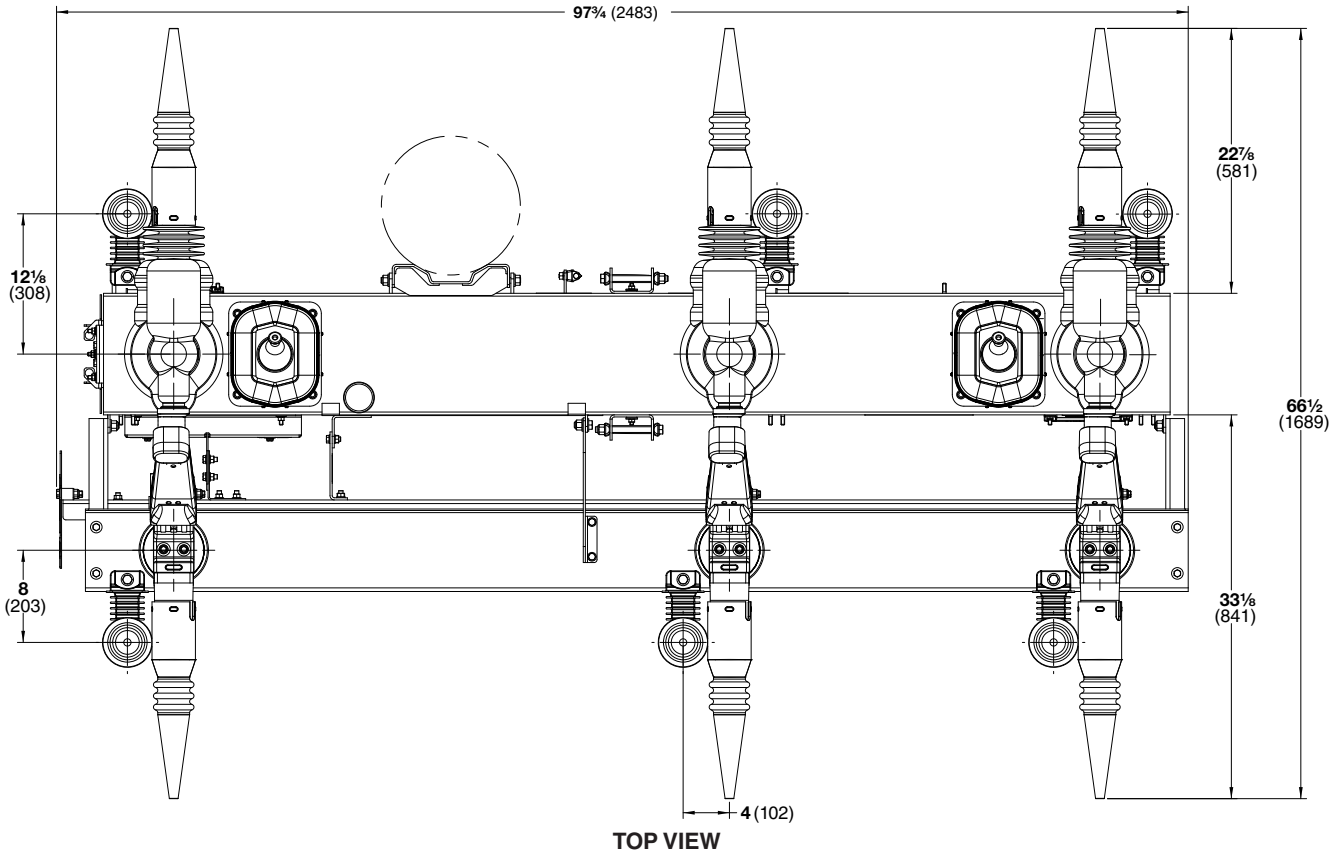

IntelliRupter® PulseCloser® Fault Interrupter

Dimensions in inches (mm)

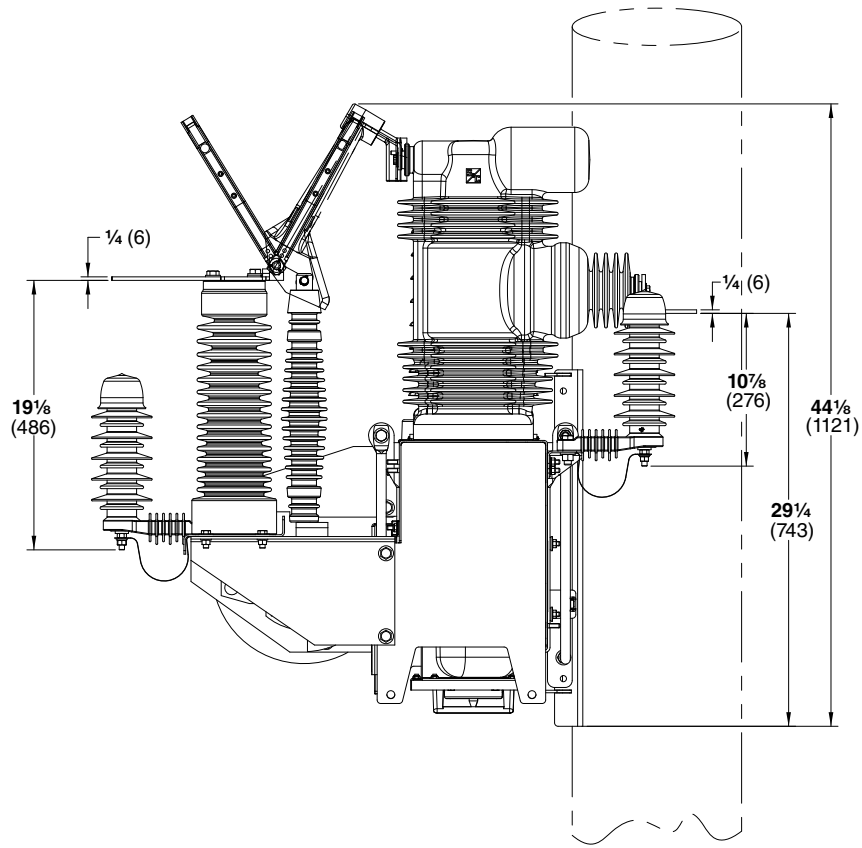

SIDE VIEW

IntelliRupter® PulseCloser® Fault Interrupter

Disconnect-Style 38-kV IntelliRupter Fault Interrupter

Upright-Crossarm Mounting Configuration, ED-857

(top and front views shown without optional wildlife protection, catalog number suffix "-W2")

Dimensions in inches (mm)

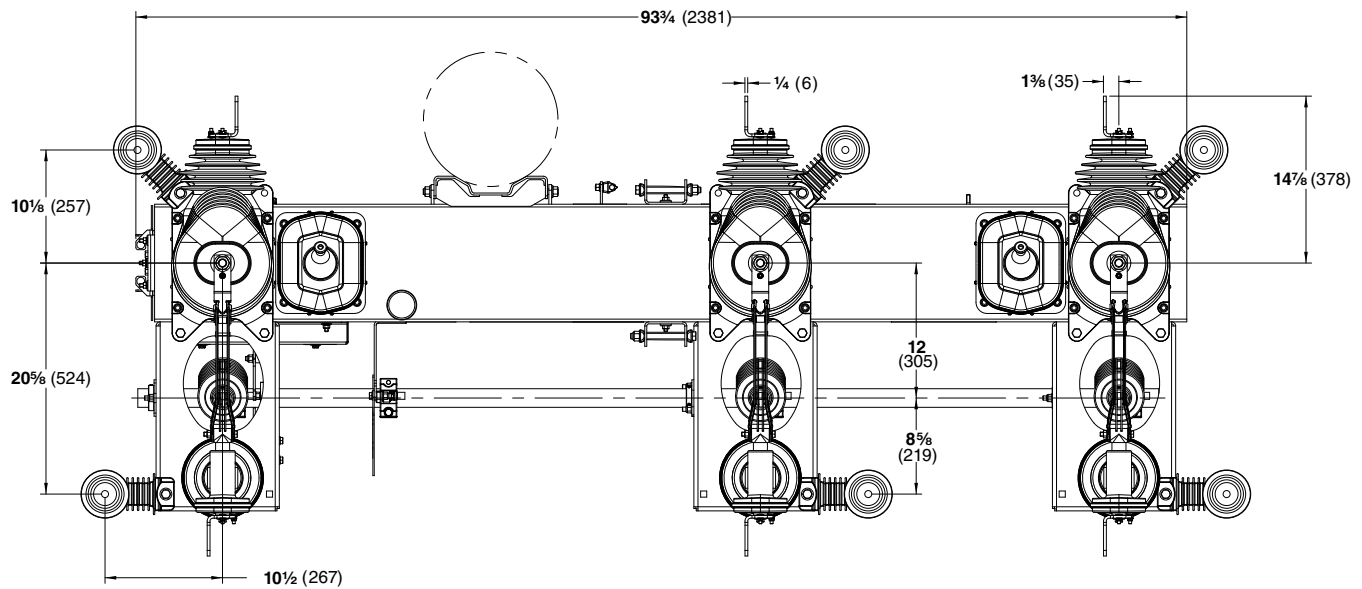

TOP VIEW

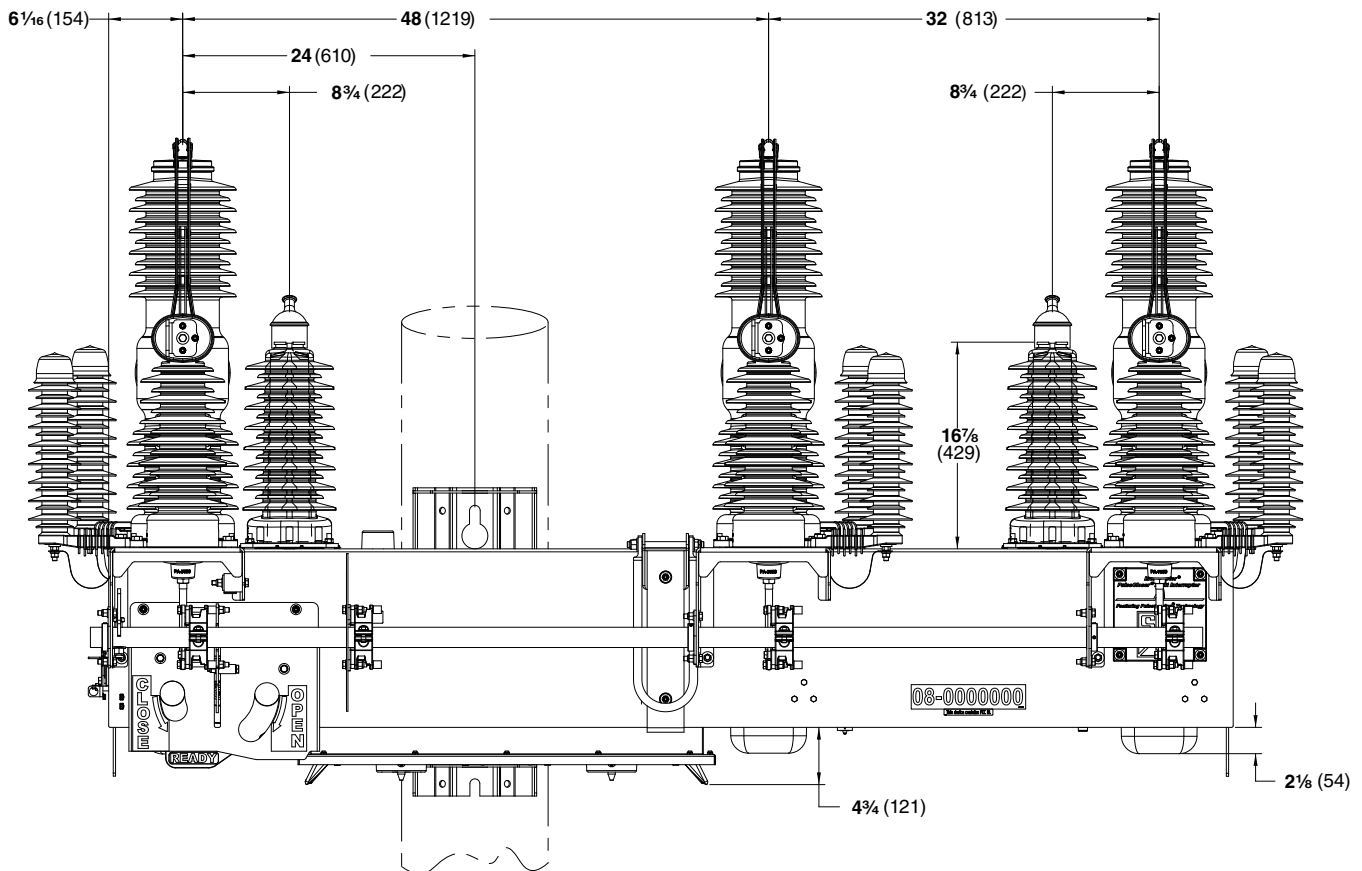

FRONT VIEW

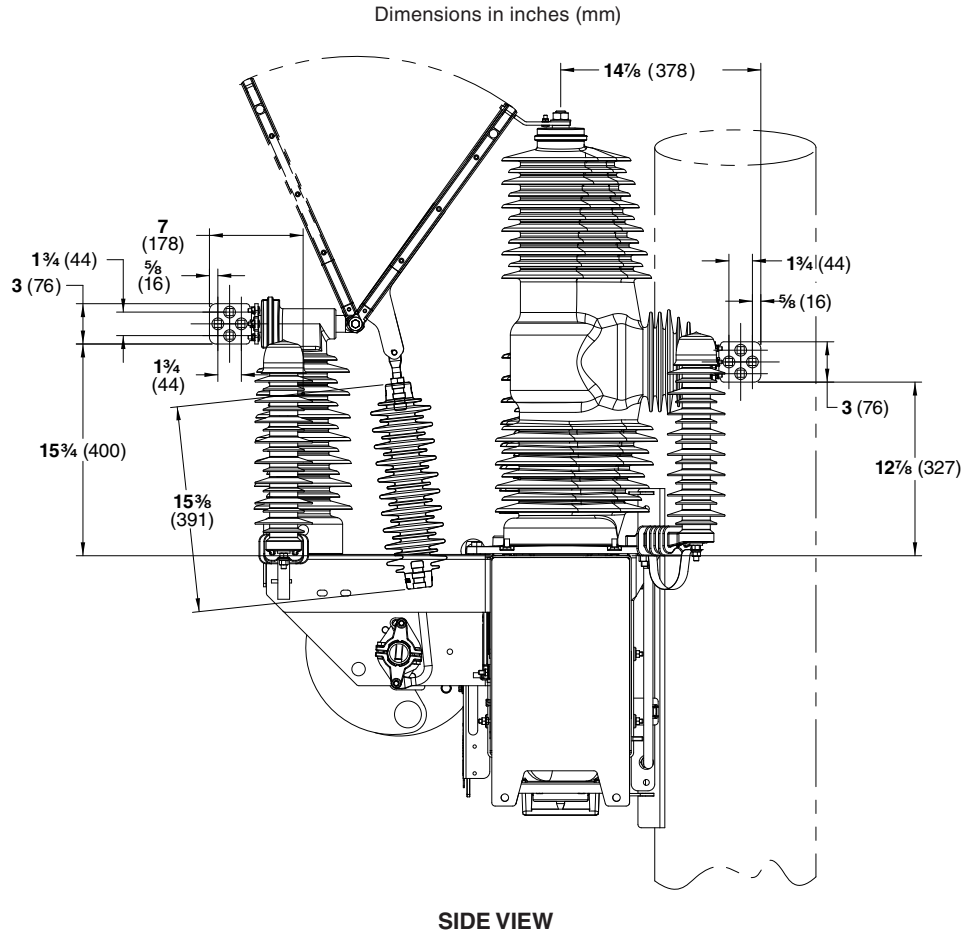

Pole-Saddle

Dimensions in inches (mm)

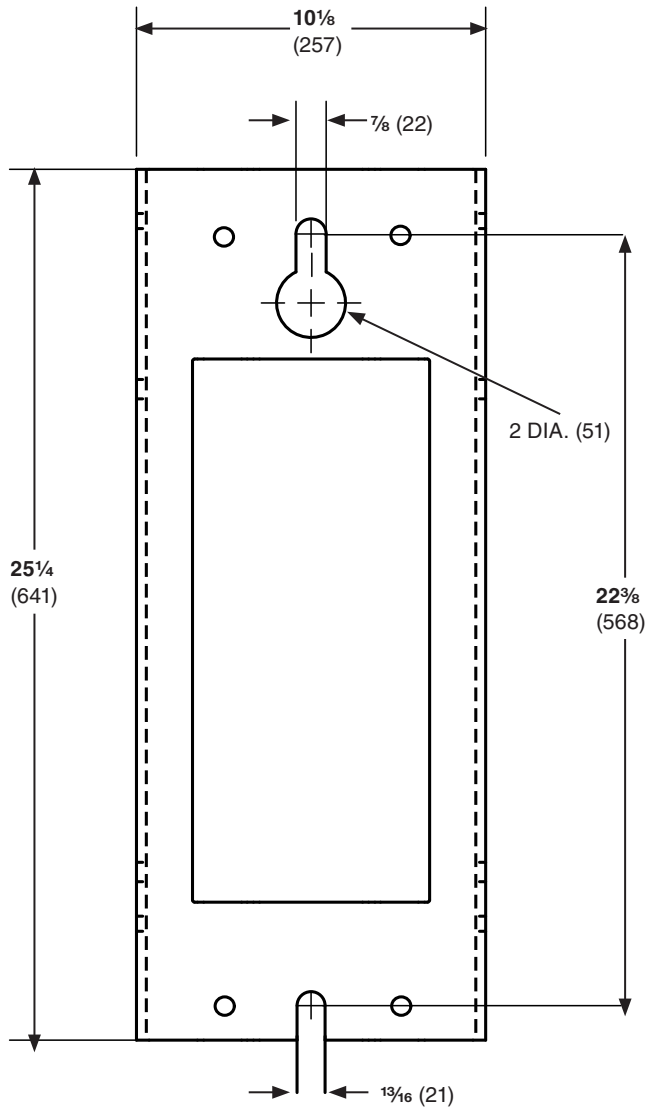

15-kV and 27-kV IntelliRupter Fault Interrupter

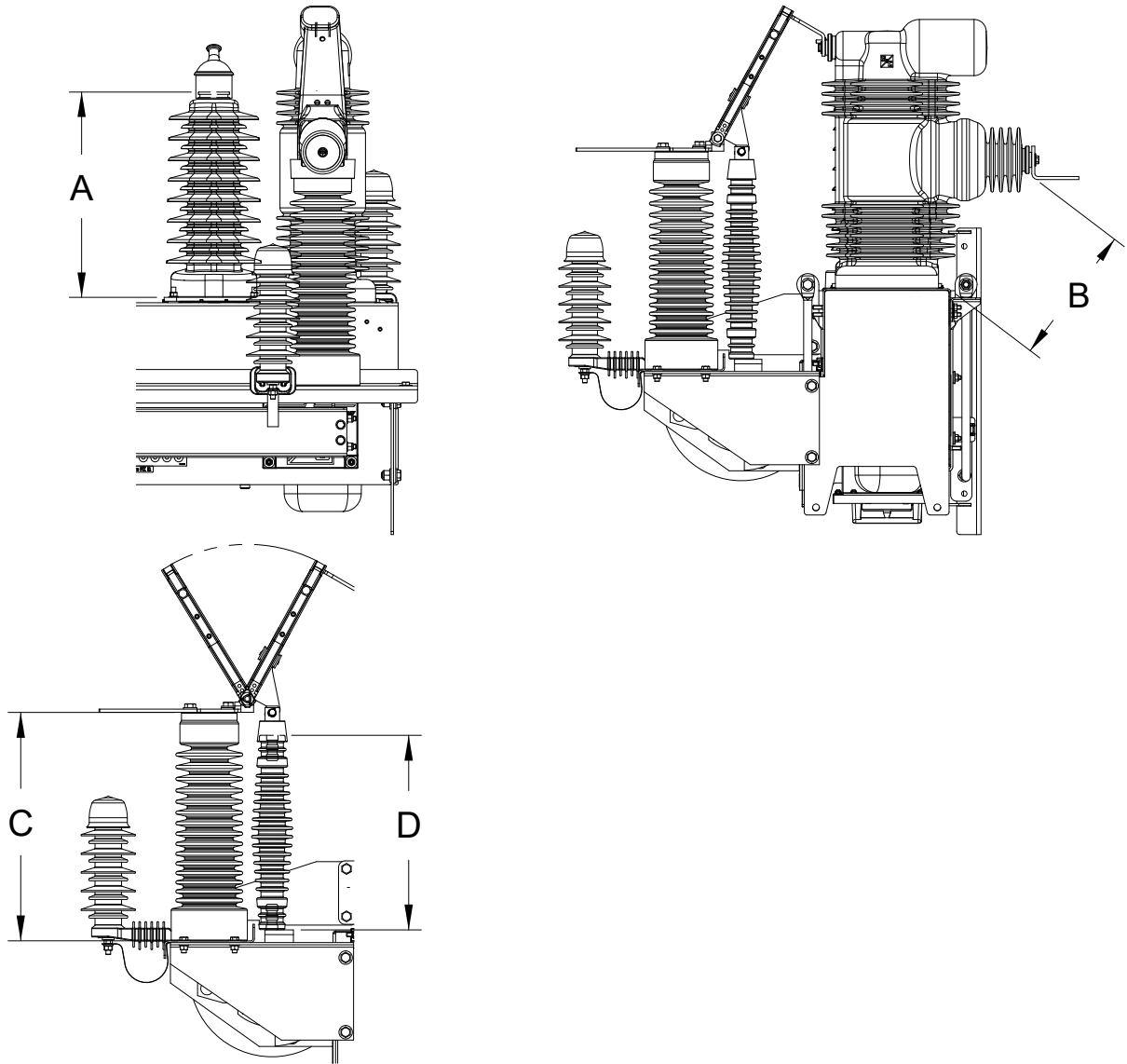

Dimension	Description	Dry Arcing Distance, inches (mm) ^①	Leakage Distance, inches (mm) ^②	Leakage at 15 kV, mm/kV ^②	Leakage at 27 kV, mm/kV ^②
A	Integral power module	16½ (419)	34 (864)	57⅝	32
B	Interrupter	11½ (292)	38 (965)	64¼	35¾
C	Insulator	18 (457)	37 (940)	62⅝	34¾
D	Push rod	15⅝ (389)	31¼ (794)	53	29⅝

① Dry arcing distance is the shortest distance between the metal surfaces separated by the insulator.

② Leakage is the distance along the surface of the insulator.

38-kV IntelliRupter Fault Interrupter

Dimensions in inches (mm)

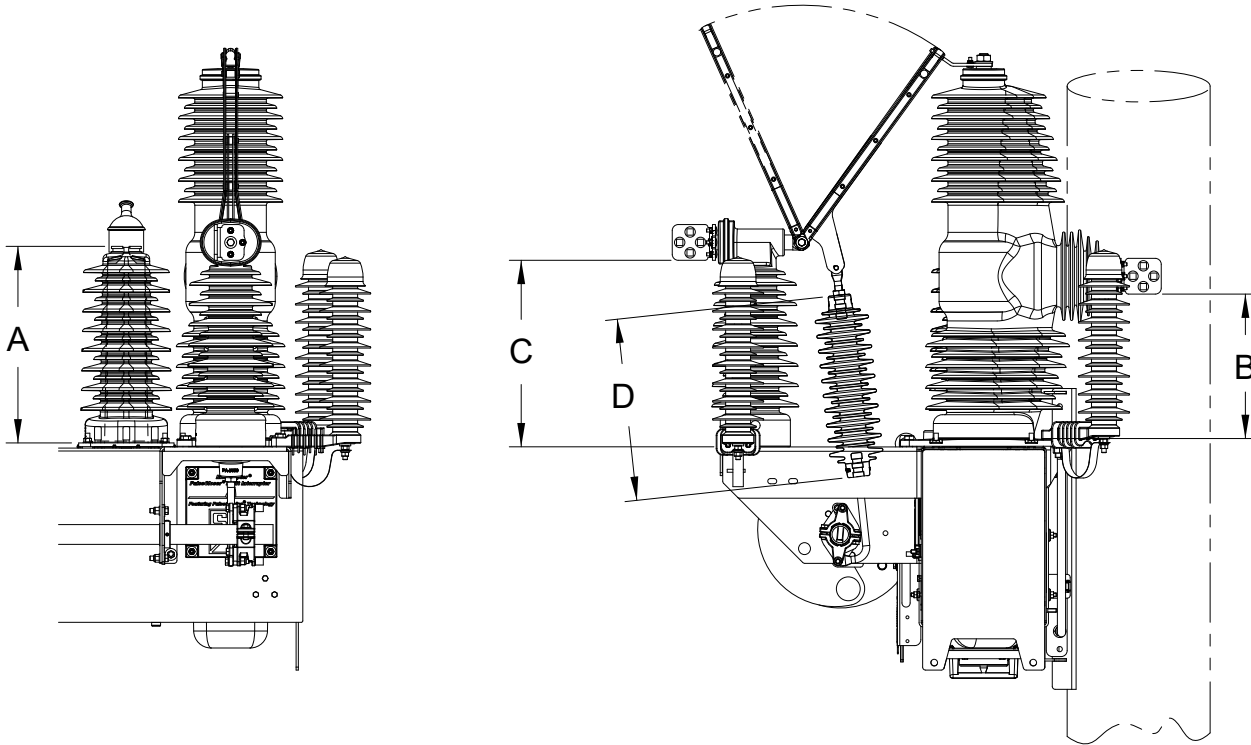

Dimension	Description	Dry Arcing Distance, inches (mm) ^①	Leakage Distance, inches (mm) ^②	Leakage at 38 kV, mm/kV ^②
A	Integral power module	16½ (419)	46¾ (1178)	31
B	Interrupter	12½ (308)	46¾ (1178)	31
C	Insulator	15¾ (397)	46¾ (1178)	30¼
D	Push rod	15¼ (387)	47½ (1207)	31¾

① Dry arcing distance is the shortest distance between the metal surfaces separated by the insulator.

② Leakage is the distance along the surface of the insulator.

SDA-4540 Protection and Control Module

Weight 21 lbs. (9.53 kg)

SDA-4554 Communication Module

Weight 26 lbs. (11.79 kg) (with battery, less communication device)

Specifications for Communication Device

Maximum size, including connectors:

9½ inches (241.3 mm) deep, 6¼ inches (158.8 mm) wide,
3¾ inches (95.3 mm) high

Voltage: 10.5–15.9 Vdc

Maximum allowable average continuous power when using
integral power modules:

≤8 watts over a 10-second interval

Peak transient current: 2 amperes for 500 milliseconds

Maximum allowable average continuous power when using an
external power supply:

≤20 watts over a 10-second interval

Peak transient current: 2 amperes for 500 milliseconds

